



Use Cases

Designing 5G and mmWave Microwave Filters with an AI-Optimized Design Platform.

SYNMATRIX



Table of Contents



1. **Use Case 1: Computer-Aided Tuning Design**
2. **Use Case 2: AI Optimized Design Platform**
 - ***Use Case 2a:*** Coaxial Cavity Structure using Space Mapping method
 - ***Use Case 2b:*** Waveguide Structure using AI-optimized method
 - ***Use Case 2c:*** Dielectric Filled Waveguide using AI-optimized method



Use Case 1: Computer Aided Tuning Design

SYNMATRIX

Introducing a SynMatrix-HFSS integrated workflow for Microwave Filter Design.

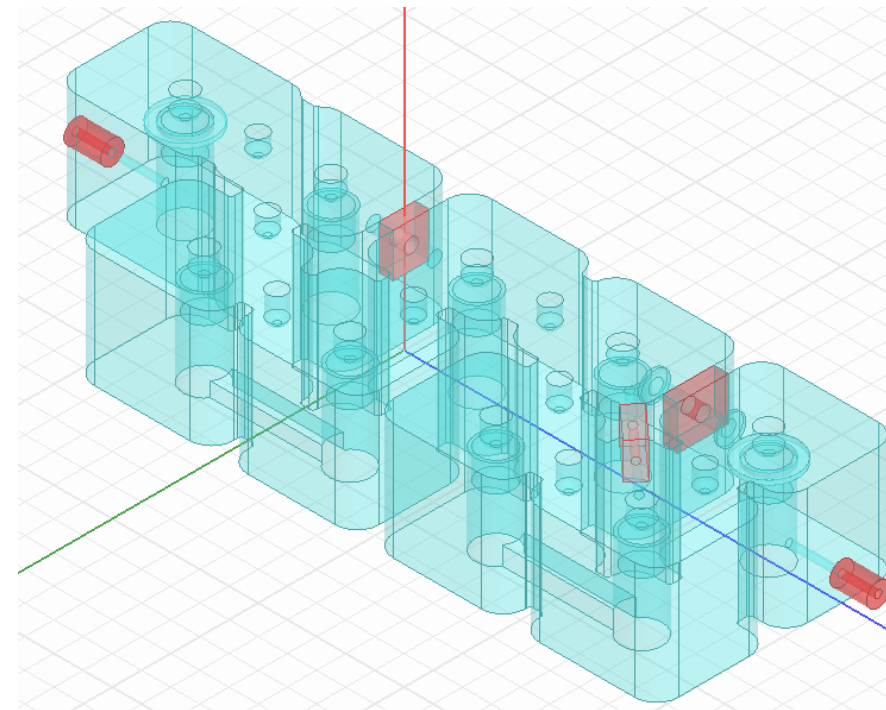

Customer Requirements

Specifications	Requirements
Frequency Range (MHz)	3300 ~ 3400
Insertion Loss (dB)	< 1.5
Rejection (MHz)	0.09 ~ 3190 > 100 dB
	3190~3280 > 40 dB
	3420~3460 > 40 dB
	3460~6800 > 80 dB
Return Loss (dB)	> 16
Peak Power (Watts)	100
Operating Temperature (°C)	-30~80
Connector Type	SMA

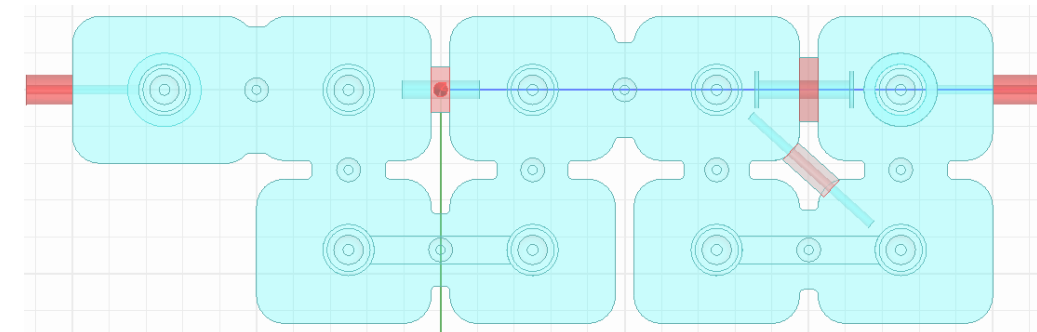
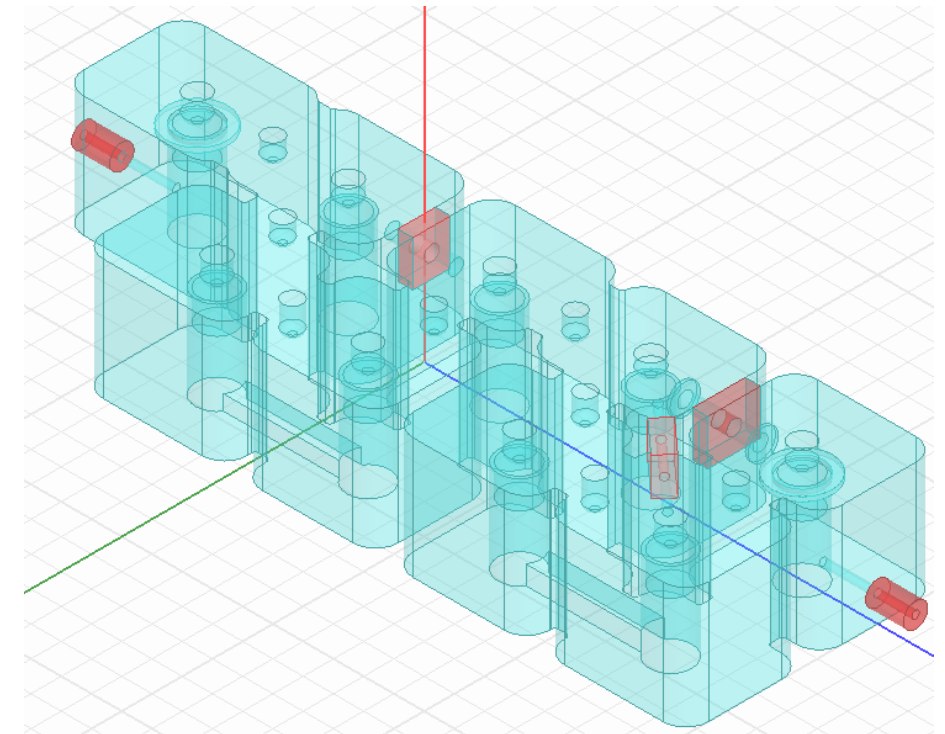

Step 1: Specification analysis and ideal filter performance design.

1

Input Parameters

Filter Order:	9	RL	20	dB
<input checked="" type="checkbox"/> FO	3.35			GHz
<input checked="" type="checkbox"/> BW	0.1			GHz
Shift	0	0		<input checked="" type="checkbox"/>
Unloaded Q	3000		All	<input type="checkbox"/>

Freq Range: 3300~3400Mhz
 Insertion Loss: < 1.5 dB
 Return Loss: > 16 dB

2

Transmission Zeros + NOR

	Zero.1	Zero.2	Zero.3	Zero.4
Pure Finite Zero (Normalized)	-1.2	1.18	2	-2.8

Rejection:
 3190~3280 > 40 dB
 3420~3460 > 40 dB
 3460~6800 > 80 dB

3

Physical Topology

Edit Topology

Filter Dispersion

1.2

Apply Dispersion

Dispersive Effect Prediction using Coaxial-type filter

4

Refresh 3.1 GHz 3.6 GHz

Display Range and associative calculation

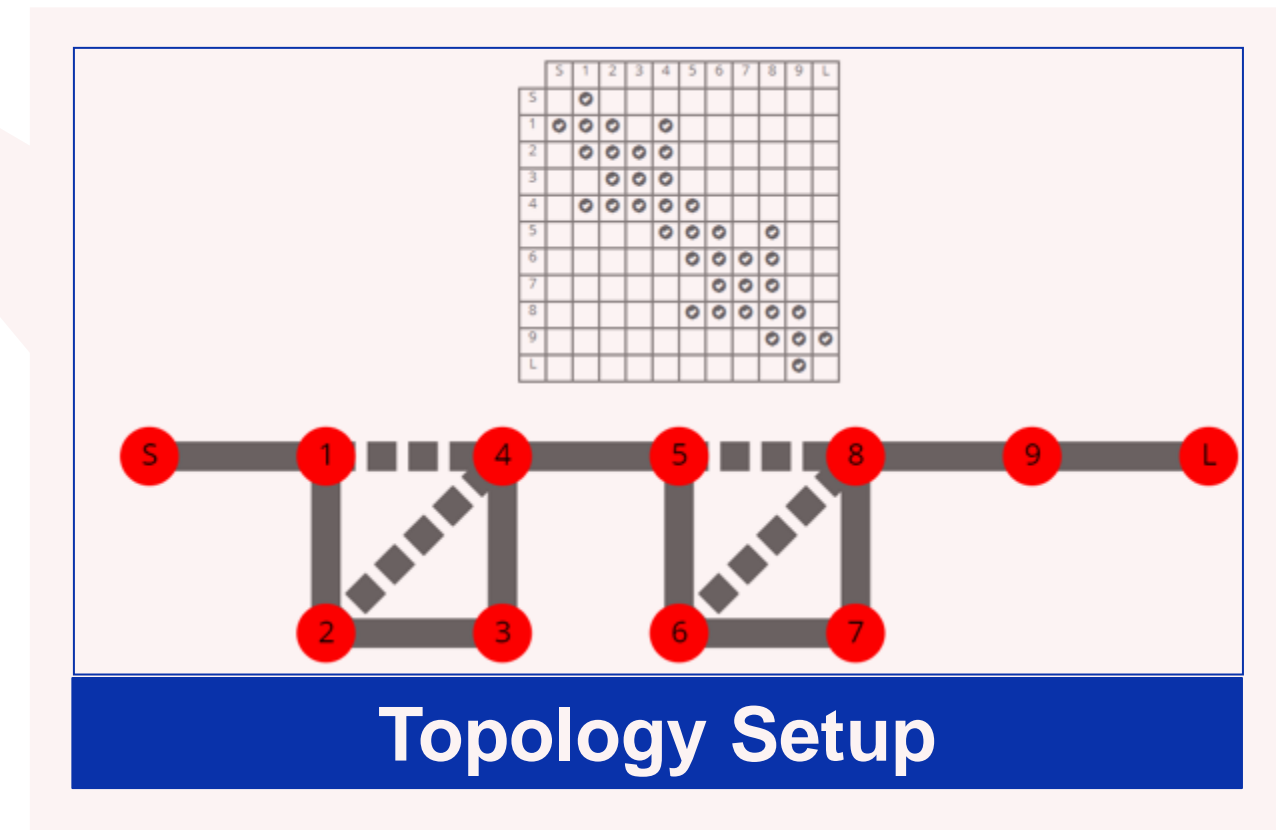

Step 1: Select material, CTE and temp range inputs for thermal shift analysis.

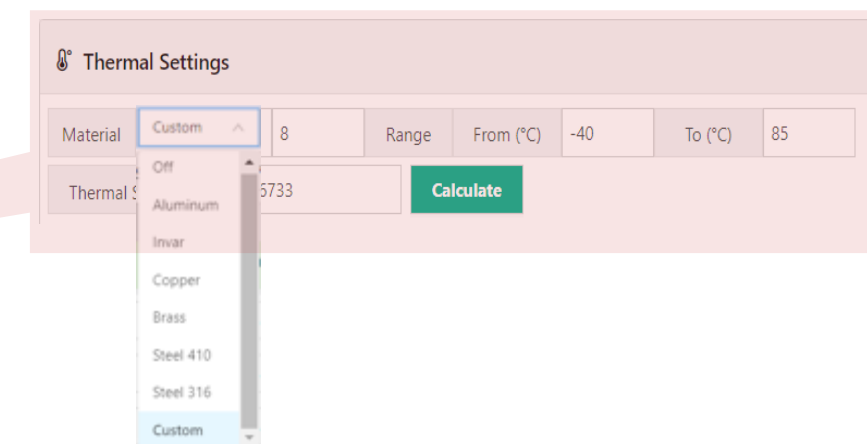
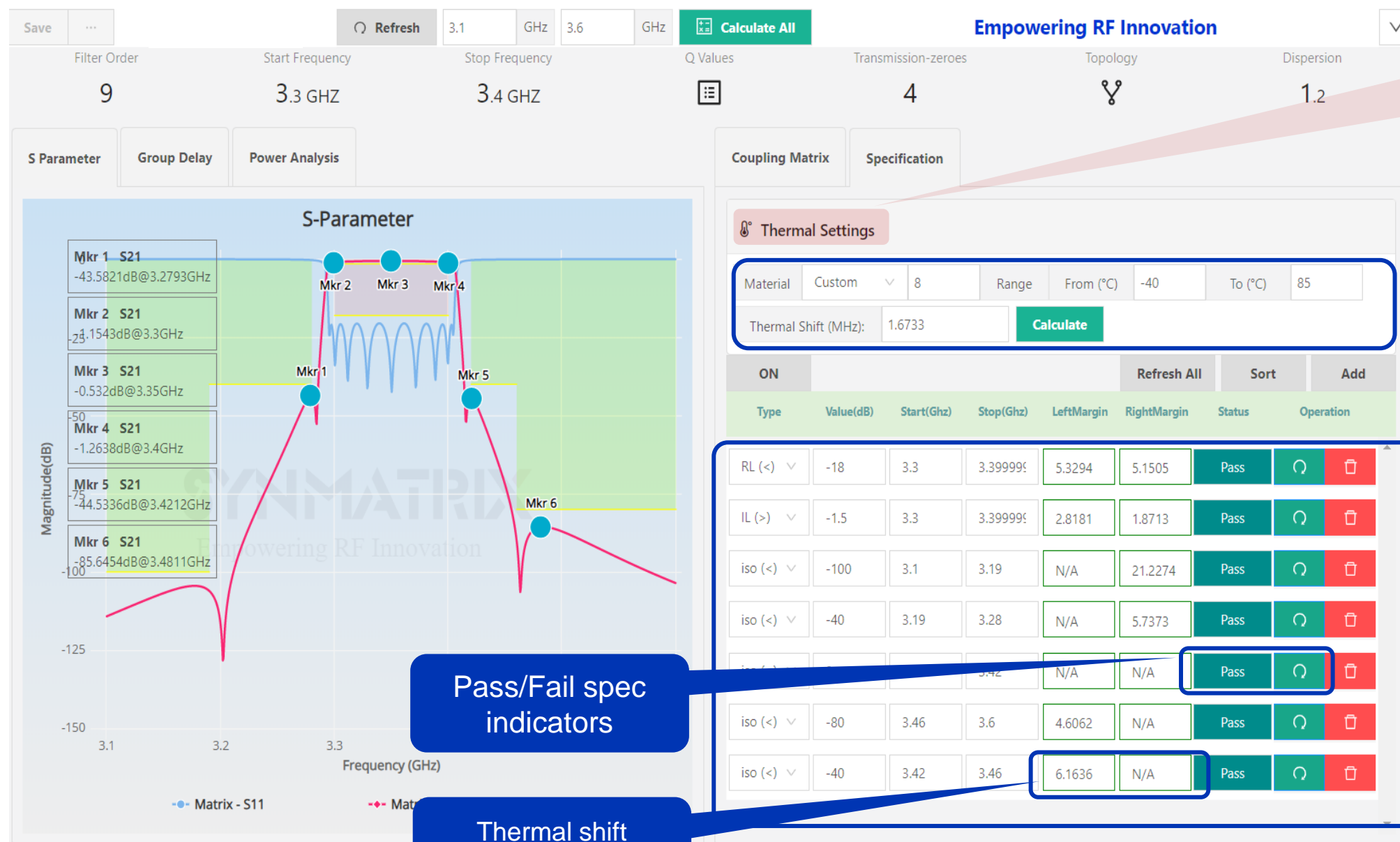

- ✓ Choose the material and perform a thermal shift analysis
- ✓ Select custom CTE number: 8ppm (based on design experience). Number will be re-evaluated in step2
- ✓ Select temp range: -35~85°C (for conservative analysis, this range should be wider than customer spec)
- ✓ Thermal shift margin: 1.67Mhz

Step 1: Graphic plots for additional feature analysis and review.

✓ Additional features allow users to analyze results from different aspects

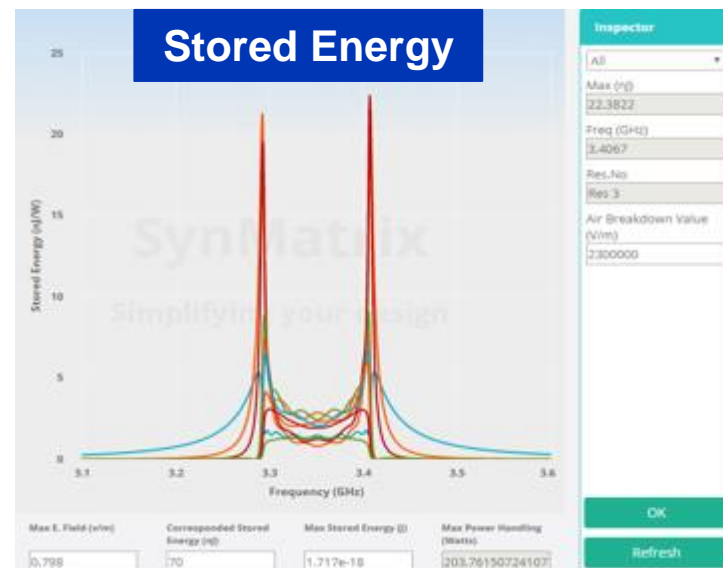
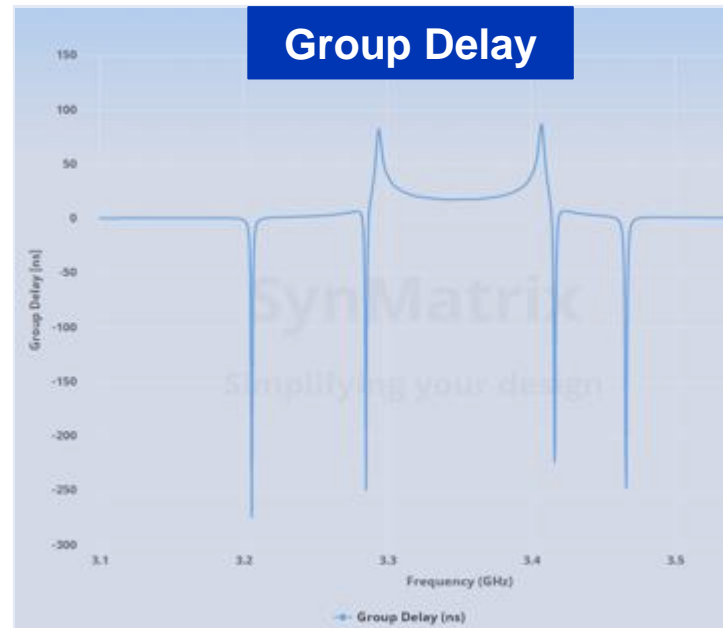

Filter Order: 9, Start Frequency: 3.3 GHz, Stop Frequency: 3.4 GHz, Q Values: [Icon], Transmission-zeros: 4, Topology: [Icon], Dispersion: 1.2

S Parameter: **Group Delay** | Power Analysis

S-Parameter

Magnitude(dB) vs Frequency (GHz)

- Mkr 1 - S21: -43.5821dB@3.2793GHz
- Mkr 2 - S21: -1.1543dB@3.3GHz
- Mkr 3 - S21: -0.532dB@3.35GHz
- Mkr 4 - S21: -1.2638dB@3.4GHz
- Mkr 5 - S21: -44.146dB@3.4212GHz
- Mkr 6 - S21: -85.6454dB@3.4811GHz

Legend: Matrix - S11 (blue), Matrix - S21 (red)

Coupling Matrix | Specification

Input GD: 5.969, ns, Output GD: 5.969, ns, NORMALIZED

S	1	2	3	4	5	6	7	8	9
S	0	1.0327	0	0	0	0	0	0	0
1	1.0327	0.0149	0.8131	0	-0.3686	0	0	0	0
2	0	0.8131	0.0311	0.8759	0.0180	0	0	0	0
3	0	0	0.8759	-0.0207	0.4924	0	0	0	0
4	0	-0.3686	0.0180	0.4924	0.0159	0.5778	0	0	0
5	0	0	0	0.5778	0.0175	0.5791	0	-0.0367	0
6	0	0	0	0	0.5791	0.0281	0.6266	0.0623	0
7	0	0	0	0	0	0.6266	-0.1011	0.6367	0
8	0	0	0	0	-0.0367	0.0623	0.6367	0.0150	0.8928
9	0	0	0	0	0	0	0	0.8928	0.0149
L	0	0	0	0	0	0	0	0	1.0327

Coefficient Matrix

Zoom | Edit Matrix | Export | Load Matrix | Edit Sign

Step 1: The fine-tune matrix and S2P file export functions.

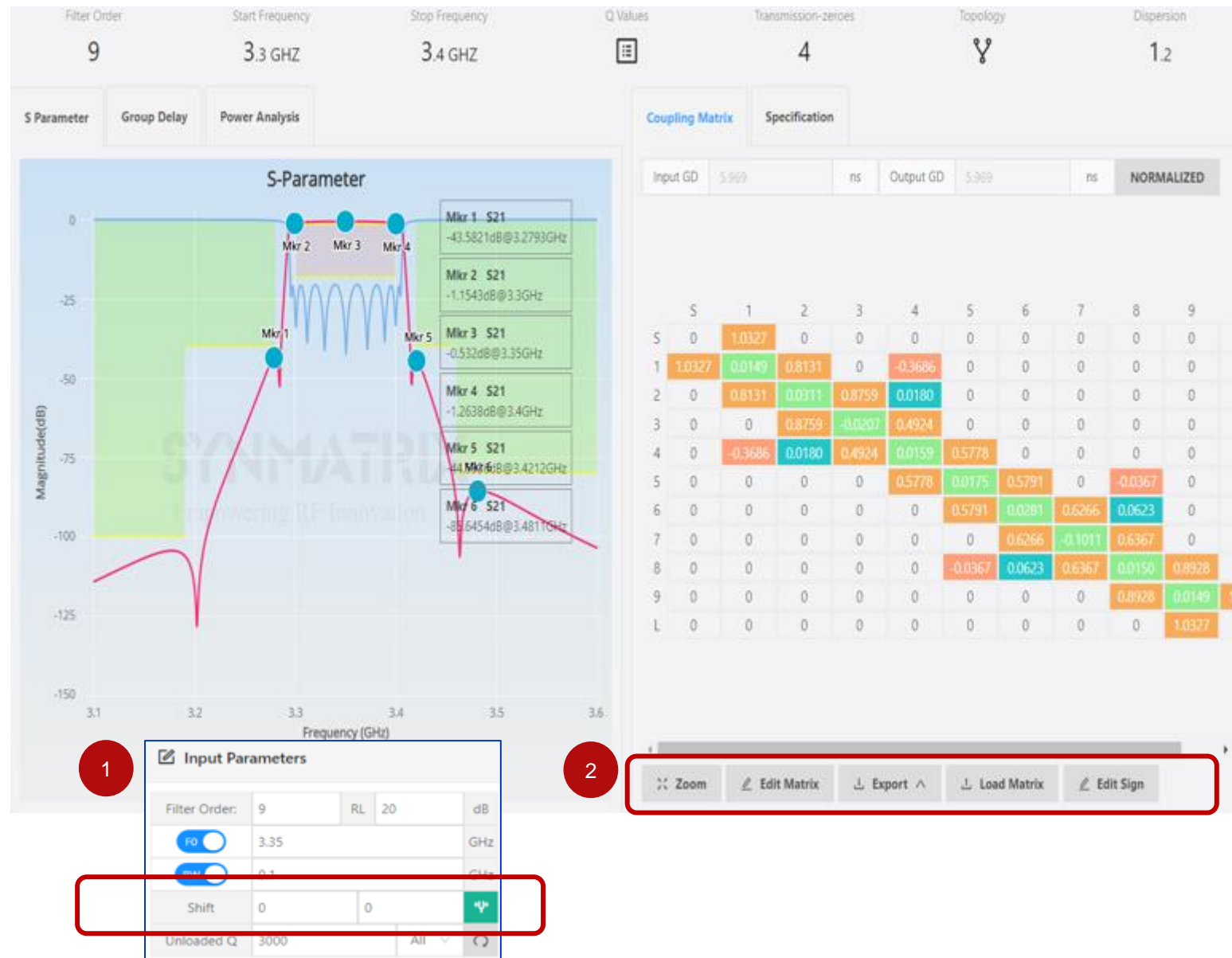

1 **Shift frequency and Bandwidth.** To meet customer requirements and to comply with thermal shift margins, the filter performance needs to be fine-tuned with the 'Fine-Tune Matrix' function without modifying the centre frequency and bandwidth.

2 **Export/Import matrix info and S2P file export.**

- Final designed matrix file can be exported
- A customized local matrix file can also be imported
- Matrix sign can be changed to adapt the different coupling schemes
- S2P file can be exported

Step 2: Single cavity simulation

Unloaded Q analysis, **thermal shift** and peak power handling estimation

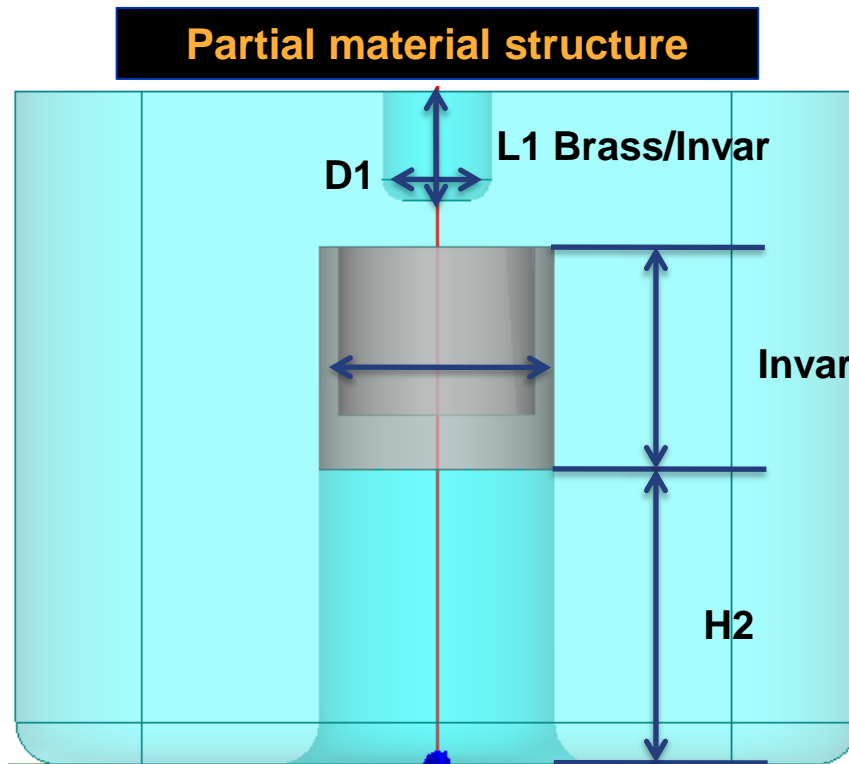

• Thermal Shift Analysis

- Compensate for frequency variation within the structure caused by temperature variation
- Invar material used on top of the resonator where electrical field is most sensitive
- For the tuning rod, the linear frequency varied range obtained within the L1 change ranges
- For partial material composed resonator, ratio between invar and aluminum need to be tuned to obtain minimum frequency variation

***To simplify the manufacturing process, only the resonator will apply to different materials**

Material	CTE (ppm/°C)
Aluminum	23
Copper	1.5
Invar	17

$$\Delta Dimension \cong Volume \times (1 + k \times CTE \times \Delta Temp)$$

*K factor may be varied based on different structures:

- By 1D dimension---length or height, factor k =1~1.5;
- By 2D dimension---area; factor k=2;
- By 3D dimension---volume, factor k=2~4;

The k factor depends on the key geometric structure, ex: tuning rod position vs. max E field

Step 2: Single cavity simulation

Unloaded Q analysis, thermal shift and peak power handling estimation

Pass Number	Solved Elements	Max Delta Freq. %
1	3095	N/A
2	4028	1.2754
3	4978	0.66362
4	6211	0.40412
5	7199	0.16259
6	8990	0.12809
7	10267	0.079078
8	11759	0.060306
9	13449	0.04906
10	15222	0.052564
11	16674	0.019631
12	18547	0.020447

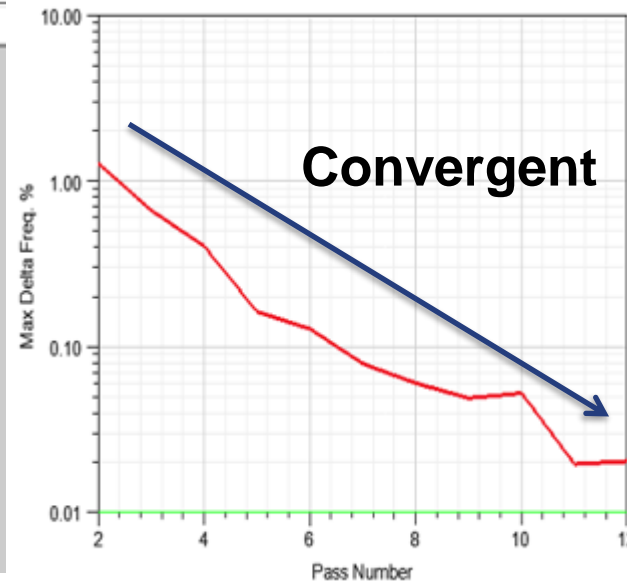

- Thermal Shift Analysis – HFSS setting**

- To avoid the frequency error during the simulation which is caused by conductive loss, the material can be assumed as a perfect electric conductor
- The “Pass Number” should be set as a reasonable higher value to ensure the simulation is accurate; in this case, the number is to set as 12
- One needs to observe the convergent status during the simulation; a bumpy curve is not allowed
- With the partial material composed resonator, the thermal shift can be control with 2.2Mhz; in the meantime, the average CTE value is around 11ppm/°C

Delta Temp (°C)	Freq-Eigenmode (Mhz)	Freq Shift—abs value (Mhz)
0	3460.88	N/A
35	3460.23	0.65
70	3459.63	1.52
100	3462.73	2.15
130	3462.98	2.10



More advanced features for thermal shift analysis will be available on SynMatrix

Step 2: Single cavity simulation

Unloaded Q analysis, **thermal shift** and peak power handling estimation

The screenshot shows the 'Thermal Settings' section of the SynMatrix software. A blue box highlights the 'Enter CTE Number' field, which is set to 8. Below it, the 'Thermal Shift (MHz)' is calculated as 1.6733. The 'Calculate' button is also highlighted. Below the settings is a table of simulation results with columns for Type, Value(dB), Start(GHz), Stop(GHz), LeftMargin, RightMargin, Status, and Operation. A blue box highlights the 'Thermal Shift Margins' column, and another blue box highlights the 'Pass / Fail Status' column.

Type	Value(dB)	Start(GHz)	Stop(GHz)	LeftMargin	RightMargin	Status	Operation
RL (<)	-18	3.3	3.399999	5.3294	5.1505	Pass	🔄 🗑️
IL (>)	-1.5	3.3	3.399999	2.8181	1.8713	Pass	🔄 🗑️
iso (<)	-100	3.1	3.19	N/A	21.2274	Pass	🔄 🗑️
iso (<)	-40	3.19	3.28	N/A	5.7373	Pass	🔄 🗑️
iso (<)	0			N/A	N/A	Pass	🔄 🗑️
iso (<)	-80			4.6062	N/A	Pass	🔄 🗑️
iso (<)	-40	3.42	3.46	6.1636	N/A	Pass	🔄 🗑️

- **Thermal Shift Analysis – Re-evaluation in SynMatrix**

- Re-enter the CTE number retrieved from HFSS. Once complete, all the thermal margins will be displayed
- The coupling matrix needs to be fine-tuned until all the specifications are met

Step 2: Single cavity simulation

Unloaded Q analysis, thermal shift and **peak power handling estimation**

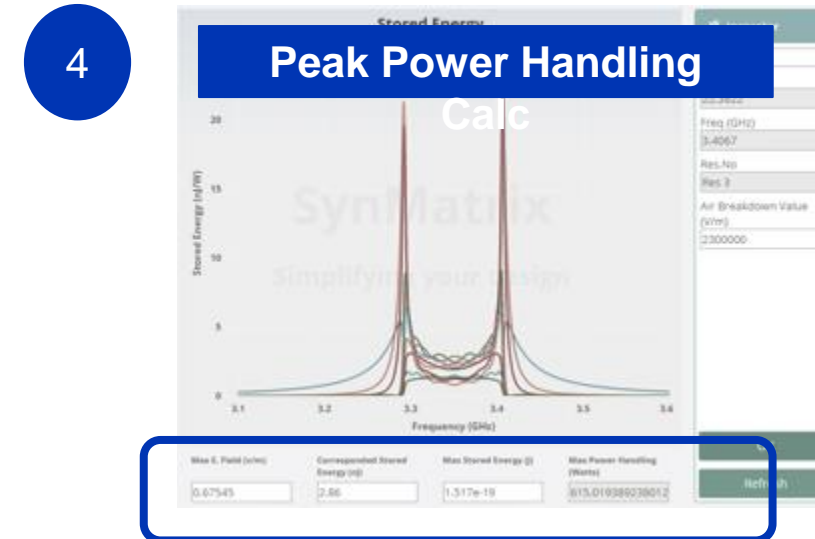
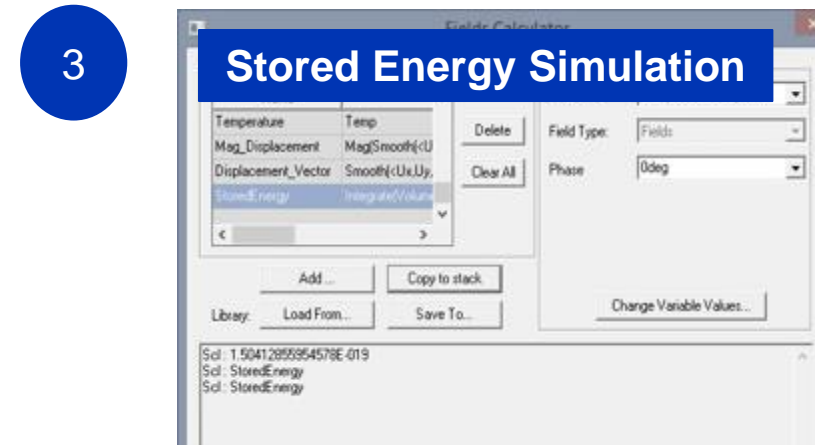
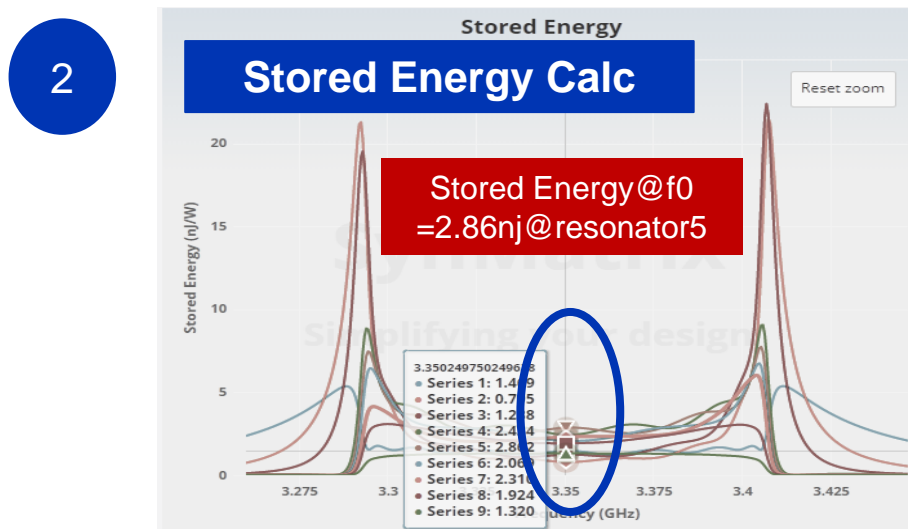
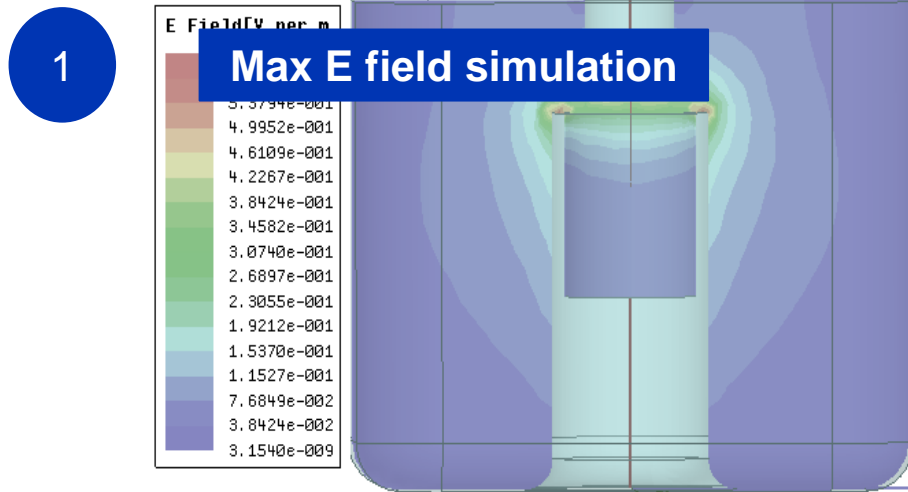

Peak Power Handling

- FOUR step calculation for peak power handling estimation
- At centre frequency, the peak power handling capability is around 615 Watts without considering the impact of power reflection

Step 3: 3D Simulation

Coupling coefficients and I/O Structure

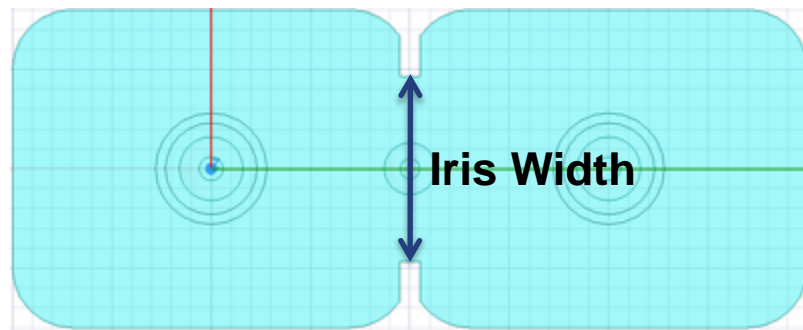

Coupling Scheme 1

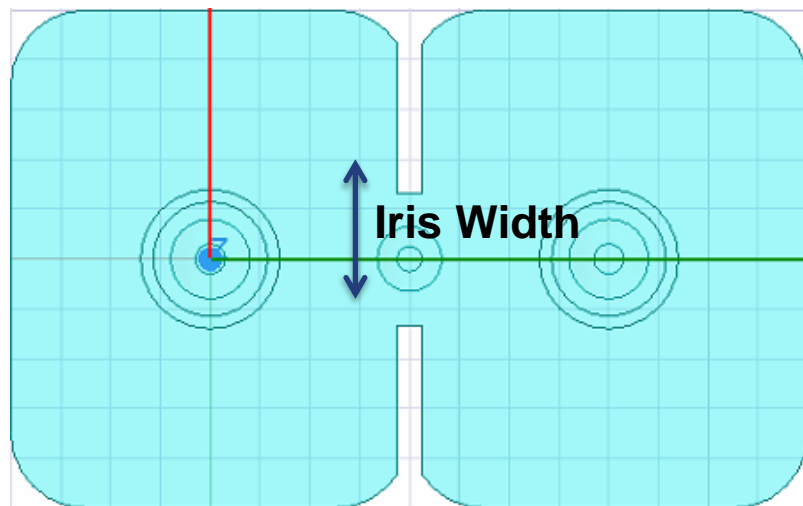
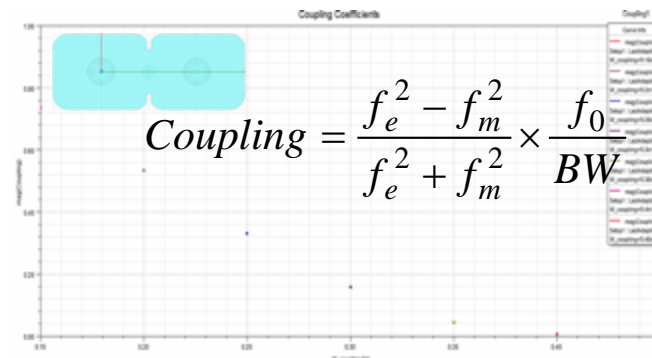

Coupling Scheme 2

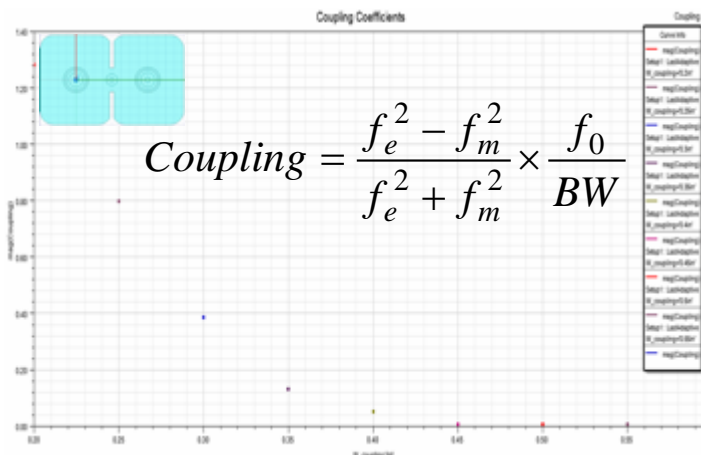

S	1	2	3	4	5	6	7	8	9	L
S	0	1.0327	0	0	0	0	0	0	0	0
1	1.0327	0.0149	0.8131	0	-0.3686	0	0	0	0	0
2	0	0.8131	0.0514	0.8759	0.0180	0	0	0	0	0
3	0	0	0.8759	-0.0287	0.4924	0	0	0	0	0
4	0	-0.3686	0.0180	0.4924	0.0159	0.5778	0	0	0	0
5	0	0	0	0	0.5778	0.0175	0.5791	0	-0.0367	0
6	0	0	0	0	0	0.5791	0.0281	0.6266	0.0623	0
7	0	0	0	0	0	0.6266	-0.1011	0.6367	0	0
8	0	0	0	0	0	-0.0367	0.0623	0.6367	0.0150	0.8928
9	0	0	0	0	0	0	0	0.8928	0.0149	1.0327
L	0	0	0	0	0	0	0	0	1.0327	0

Golden Coupling

Coupling Coefficient Simulation

- The even mode and odd mode can be obtained under the Eigenmode simulation;
- By sweeping the iris width, the coupling coefficient varying range can be from 0.1 to 1 which can cover the coupling variation of the “Golden matrix”

Step 3: 3D Simulation

Coupling coefficients and I/O Structure

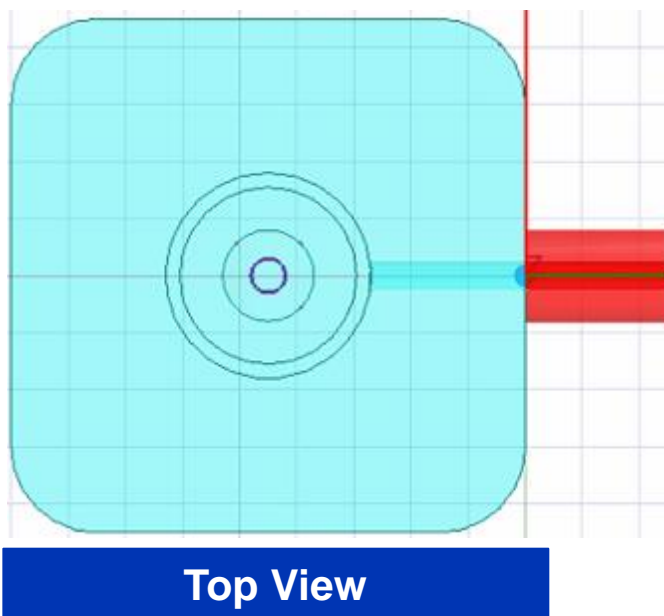
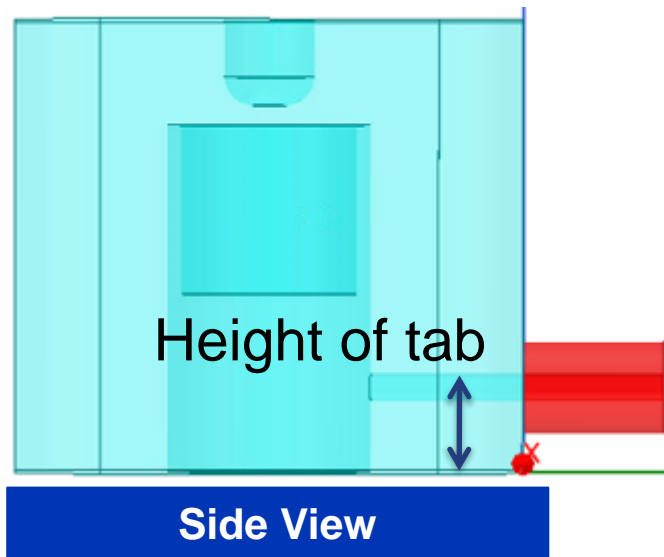

Input GD 6e-9 s Output GD 6e-9 s

GD=6ns@f0

	3	4	5	6	7	8	9	L
5	0	1.0327	0	0	0	0	0	0
1	1.0327	0.0149	0.8131	0	-0.3686	0	0	0
2	0	0.8131	0.0311	0.8759	0.0180	0	0	0
3	0	0	0.8759	-0.0207	0.4924	0	0	0
4	0	-0.3686	0.0180	0.4924	0.0159	0.5778	0	0
5	0	0	0	0	0.5778	0.0175	0.5791	0
6	0	0	0	0	0	0.5791	0.0281	0.6266
7	0	0	0	0	0	0.6266	-0.1011	0.6367
8	0	0	0	0	0	-0.0367	0.0623	0.6367
9	0	0	0	0	0	0	0.8928	0.0149
L	0	0	0	0	0	0	0	1.0327

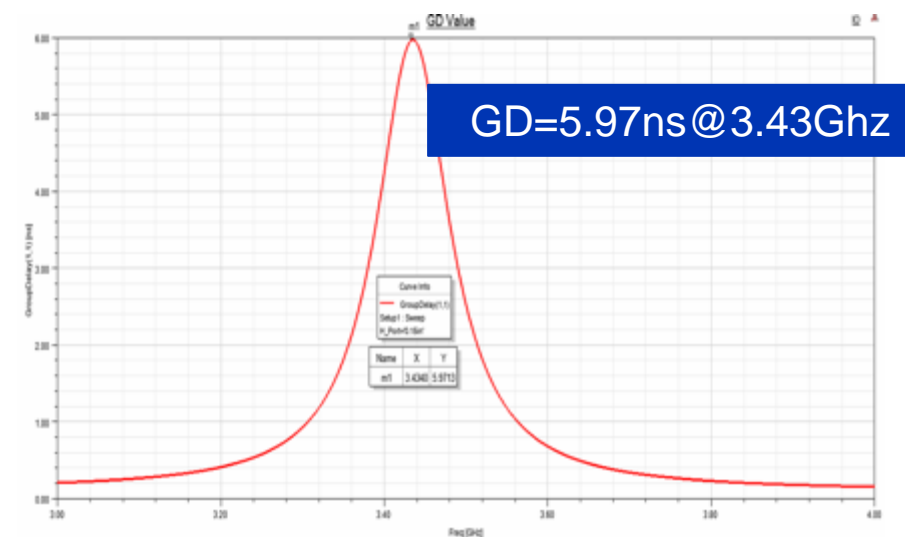

I/O Structure

- The input/output coupling can be obtained through the “Group Delay” simulation
- The relevant information can be found above the golden matrix page in Synmatrix
- Since the PIM requirement is low and the design needs higher I/O coupling, so the tab I/O structure is needed
- Due to the loading effect, the higher freq should be kept in the simulation

Step 4: 3D full EM wave simulation

Part 1 of 15

Overview

1

Step 1: Start with chebyshev type filter



2

Step 2: Add the first transmission zero

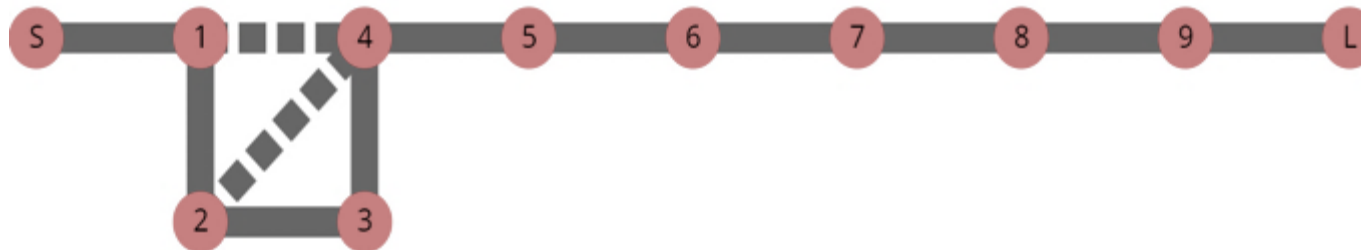

3

Step 3: The completed structure simulation

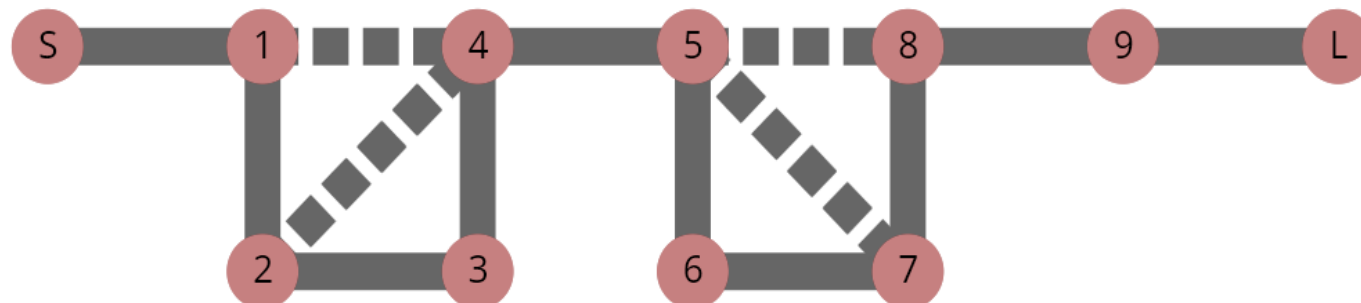

3D Fully EM wave Simulation

- The most difficult and challenging stage in the filter R&D process
- Requires design knowledge and experience
- Requires simulation time and hardware resources that can be a long, iterative and tedious process
- A good simulation will save tuning time in the pre-sampling stage, thereby lowering and saving the overall cost and cycle time
- Synmatrix offers a flexible and fast tuning process to speed up the simulation process and improve the design accuracy

Step 4: 3D full EM wave simulation

Mapping the physical dimension to coupling matrix value

1

Step 1: Start with chebyshev type filter



Mapping physical dimensions to the coupling matrix value

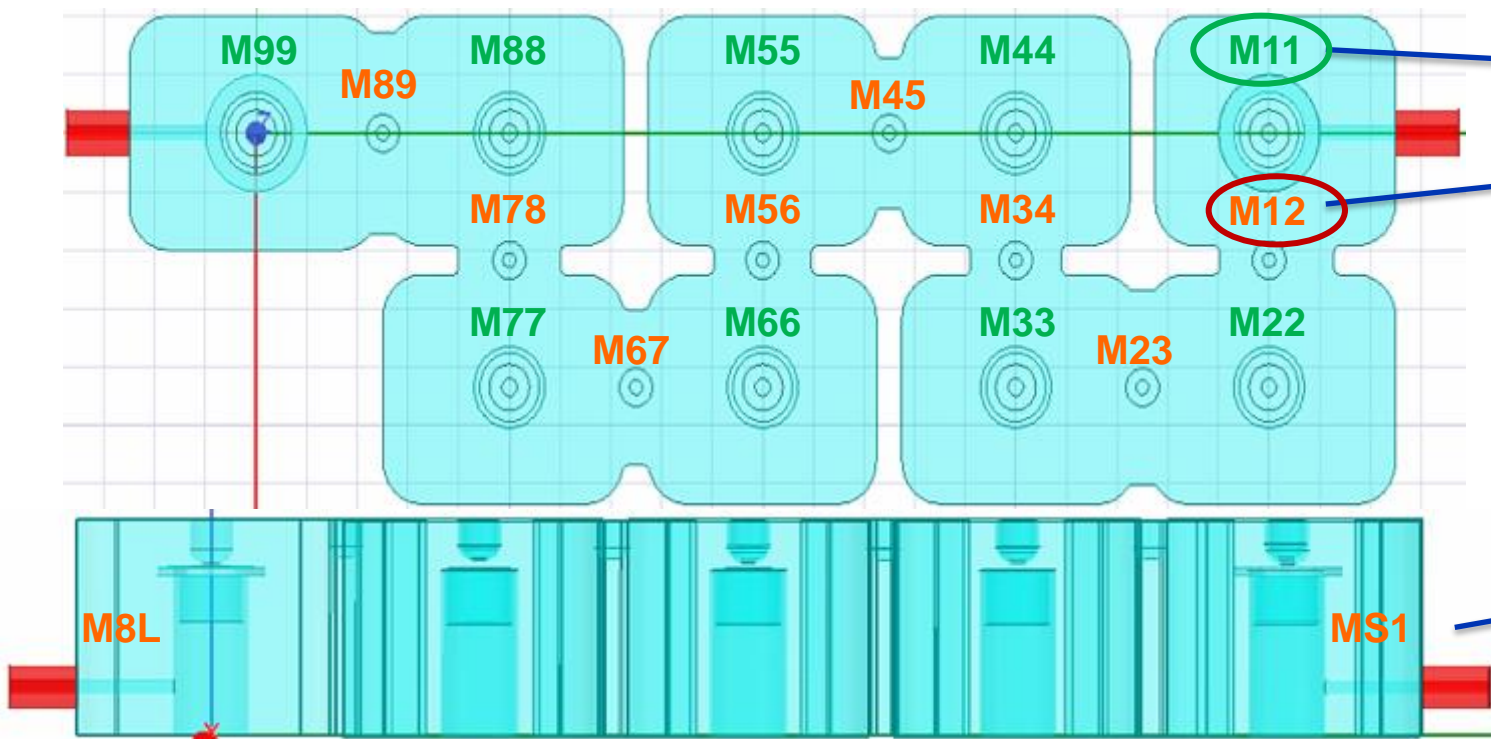

	S	1	2	3	4	5	6	7	8	9	L
S	0	1.0327	0	0	0	0	0	0	0	0	0
1	1.0327	0.0009	0.8131	0	0	0	0	0	0	0	0
2	0	0.8131	0.0171	0.8759	0	0	0	0	0	0	0
3	0	0	0.8759	0.0347	0.4924	0	0	0	0	0	0
4	0	0	0	0.4924	0.0019	0.5778	0	0	0	0	0
5	0	0	0	0	0.5778	0.0035	0.5791	0	0	0	0
6	0	0	0	0	0	0.5791	0.0141	0.6266	0	0	0
7	0	0	0	0	0	0	0.6266	-0.1151	0.6367	0	0
8	0	0	0	0	0	0	0	0.6367	0.0010	0.8928	0
9	0	0	0	0	0	0	0	0	0.8928	0.0009	1.0327
L	0	0	0	0	0	0	0	0	0	1.0327	0

Step 4: 3D full EM wave simulation

Mapping the physical dimension to coupling matrix value – Mapping Rules

Step 1: Start with chebyshev type filter

1



Mapping Rules

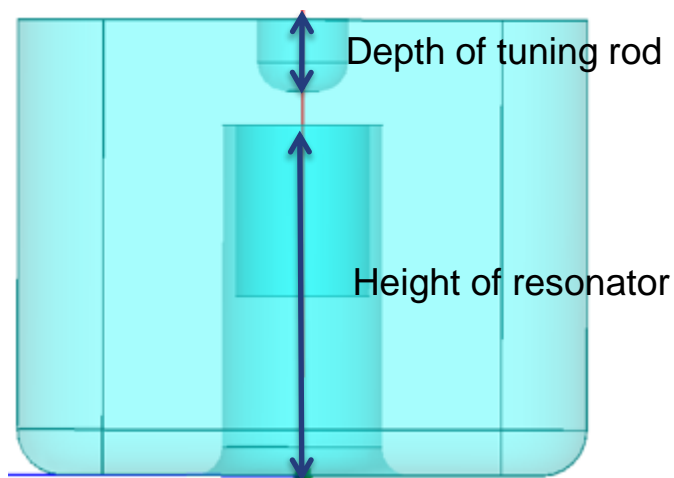

Physical Dimension for tuning the freq

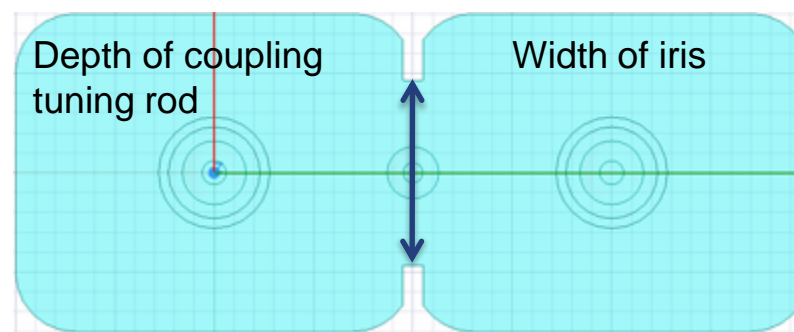

Physical Dimension for tuning coupling

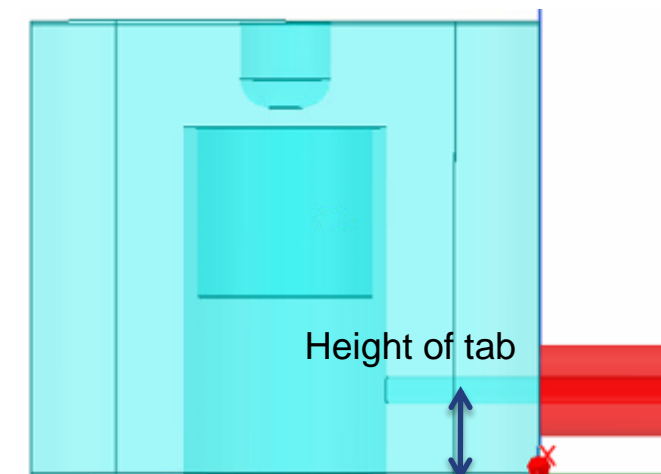

Physical Dimension for tuning the I/O

	S	1	2	3	4	Main diagonal: Freq tuning Sub-diagonal: Coupling tuning					
S	0	1.0327	0	0	0						
1	1.0327	0.0009	0.8131	0	0						
2	0	0.8131	0.0171	0.8759	0	0	0	0	0	0	
3	0	0	0.8759	-0.0347	0.4924	0	0	0	0	0	
4	0	0	0	0.4924	0.0019	0.5778	0	0	0	0	
5	0	0	0	0	0.5778	0.0035	0.5791	0	0	0	
6	0	0	0	0	0	0.5791	0.0141	0.6266	0	0	
7	0	0	0	0	0	0	0.6266	-0.1151	0.6367	0	
8	0	0	0	0	0	0	0	0.6367	0.0010	0.8928	
9	0	0	0	0	0	0	0	0	0.8928	0.0009	1.0327
L	0	0	0	0	0	0	0	0	0	1.0327	0

- There are many options for tuning; for example, a) the tuning rod depth or resonator height to tune the frequency or b) iris width or depth of coupling tuning rod for coupling tuning
- In order to ease manufacture workload, the resonator height and the coupling iris are kept at the same value (unless a change is necessary)

Step 4: 3D full EM wave simulation

Mapping the physical dimension to coupling matrix value – Start Tuning

Step 1: Start with chebyshev type filter

1

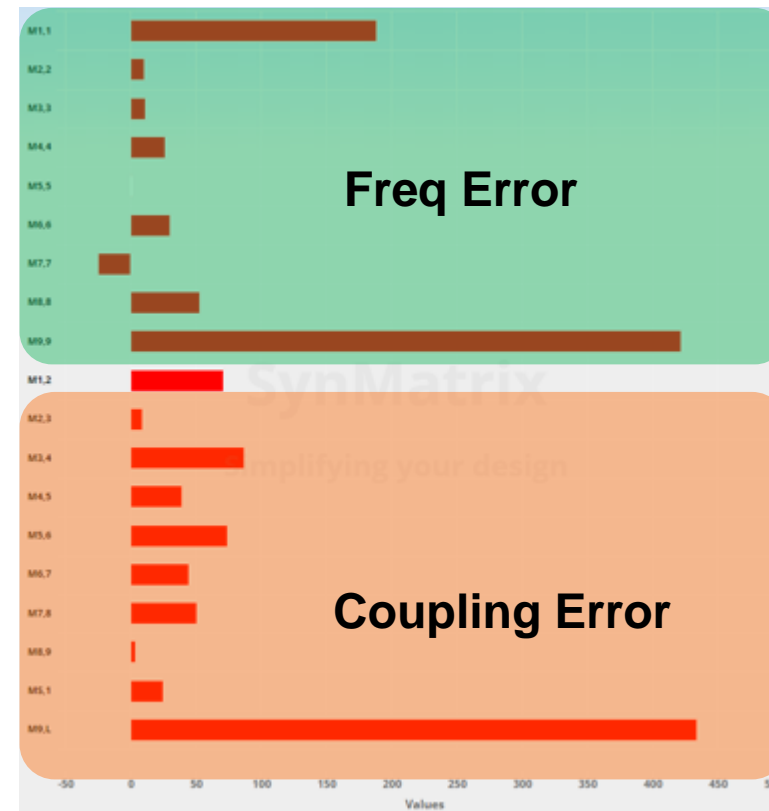
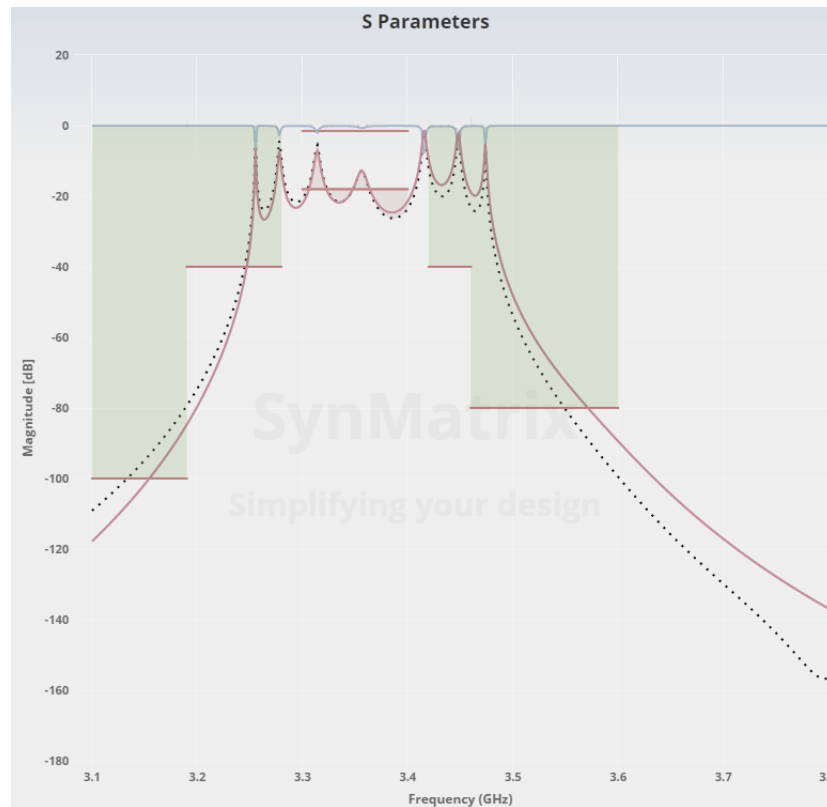

- **Frequency error:** positive error means the freq is higher while negative error means the freq is lower
- **Coupling and I/O error:** positive error means the coupling is higher while the negative error means the coupling is lower;

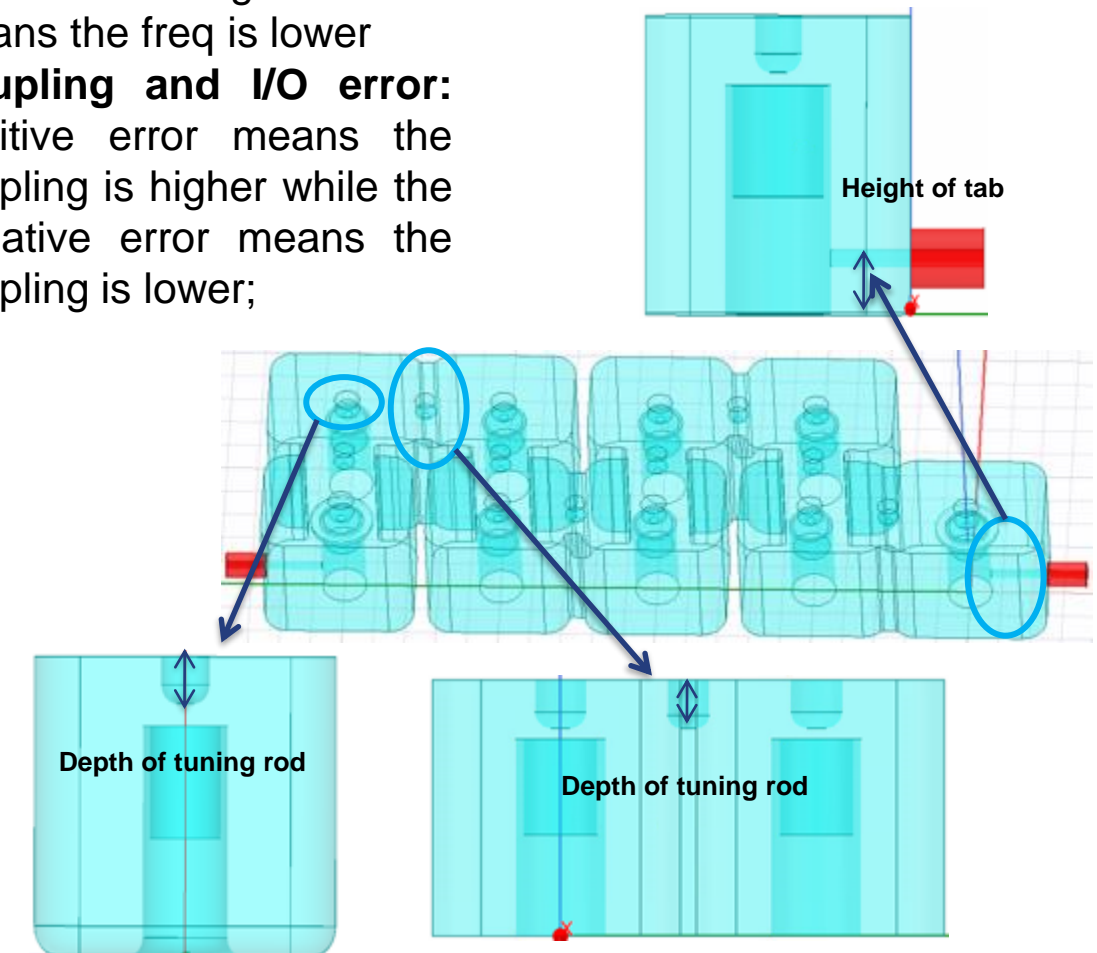

Step 4: 3D full EM wave simulation

Part 5 of 15

Mapping the physical dimension to coupling matrix value – Start Tuning

Step 1: Start with chebyshev type filter

1

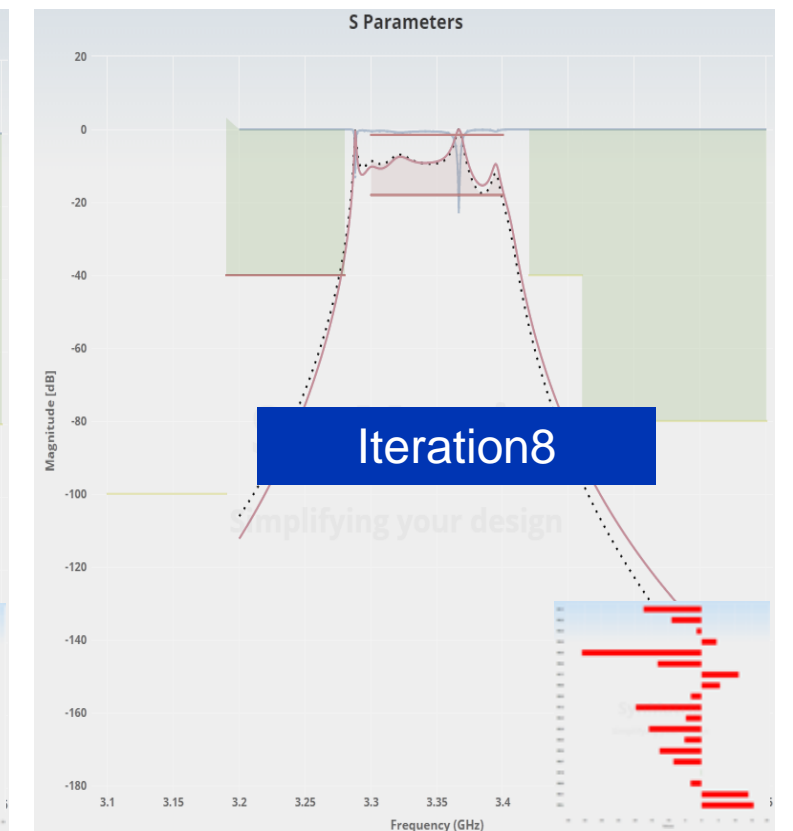
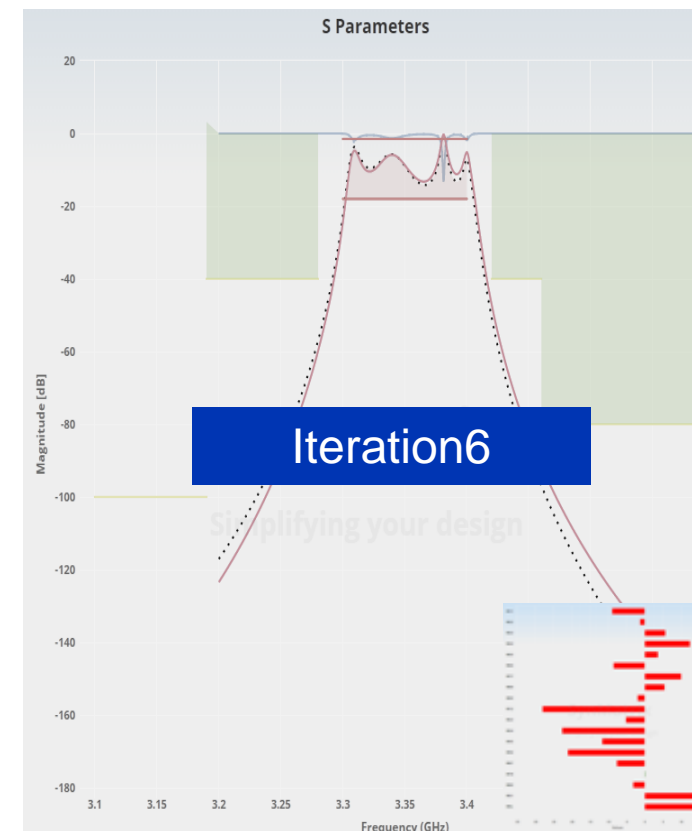
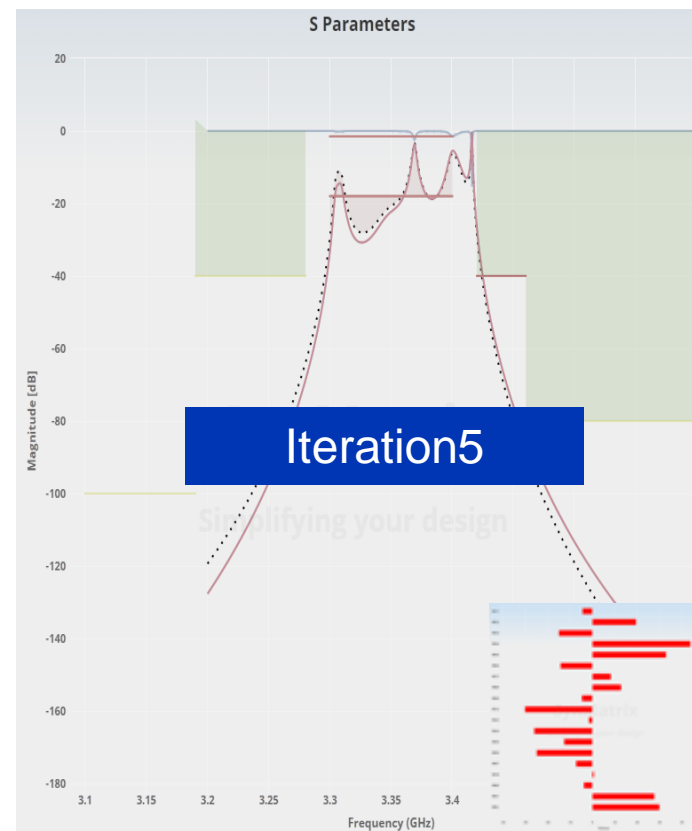
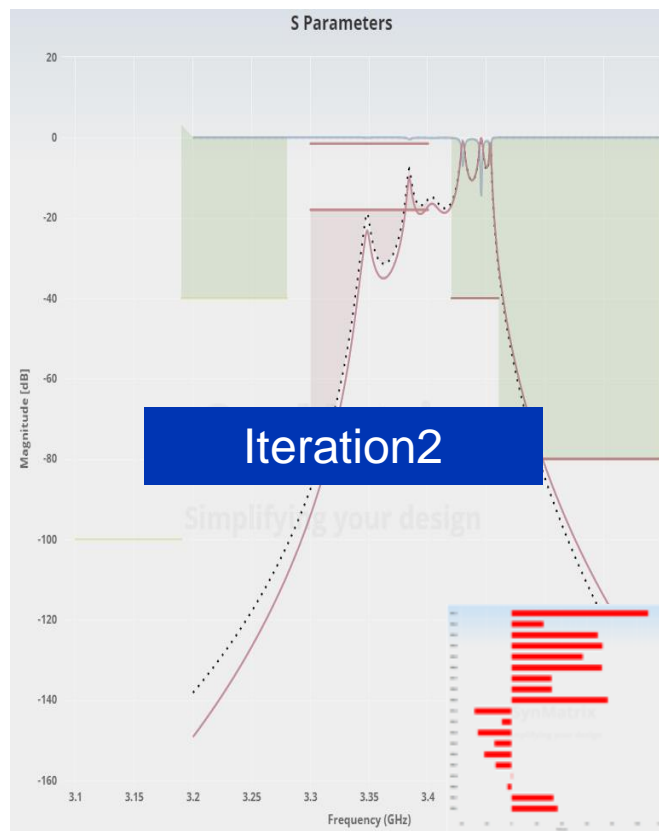

Step 4: 3D full EM wave simulation

Mapping the physical dimension to coupling matrix value – Start Tuning

1

Step 1: Start with chebyshev type filter

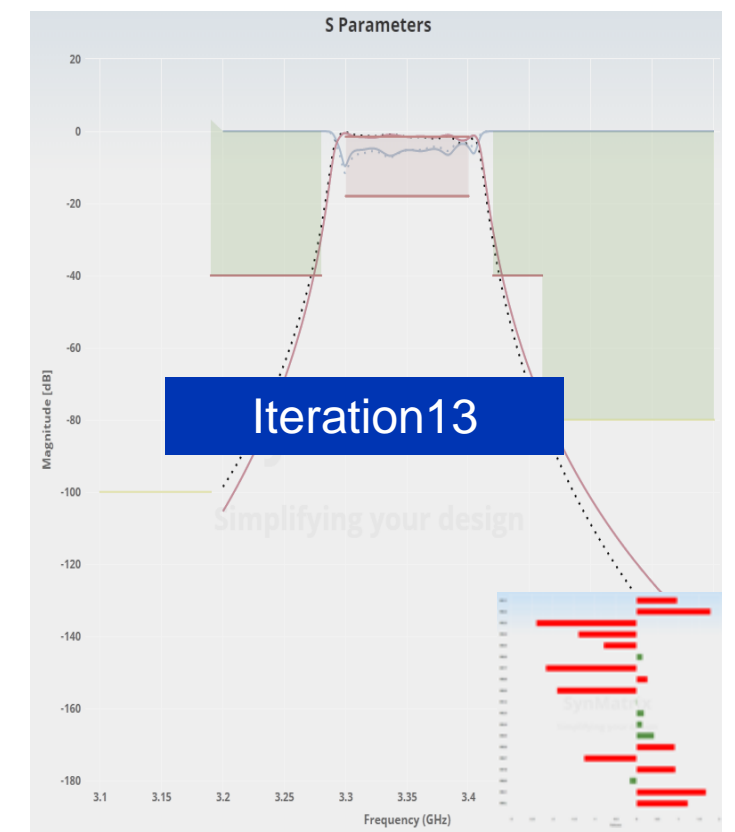
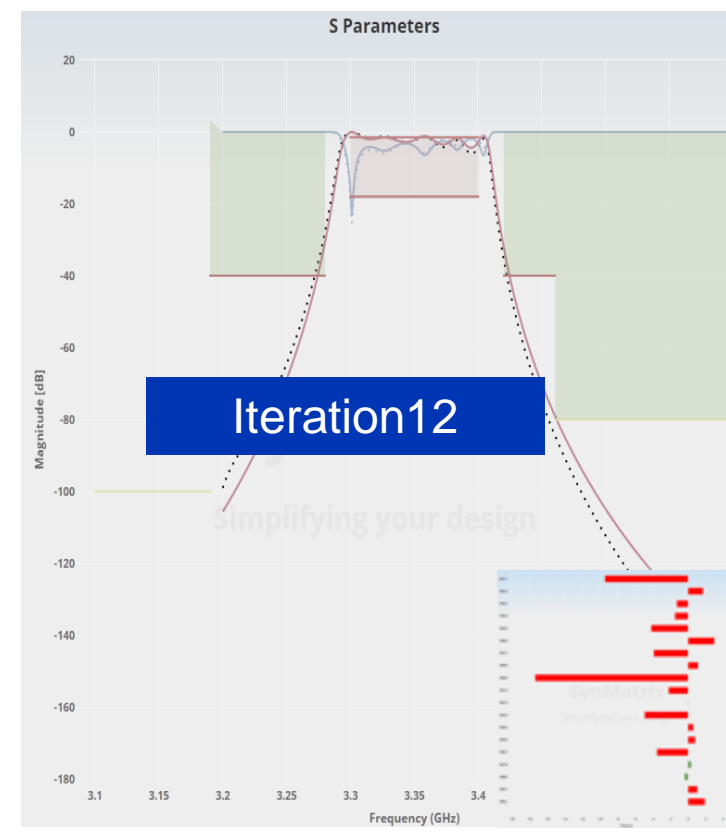
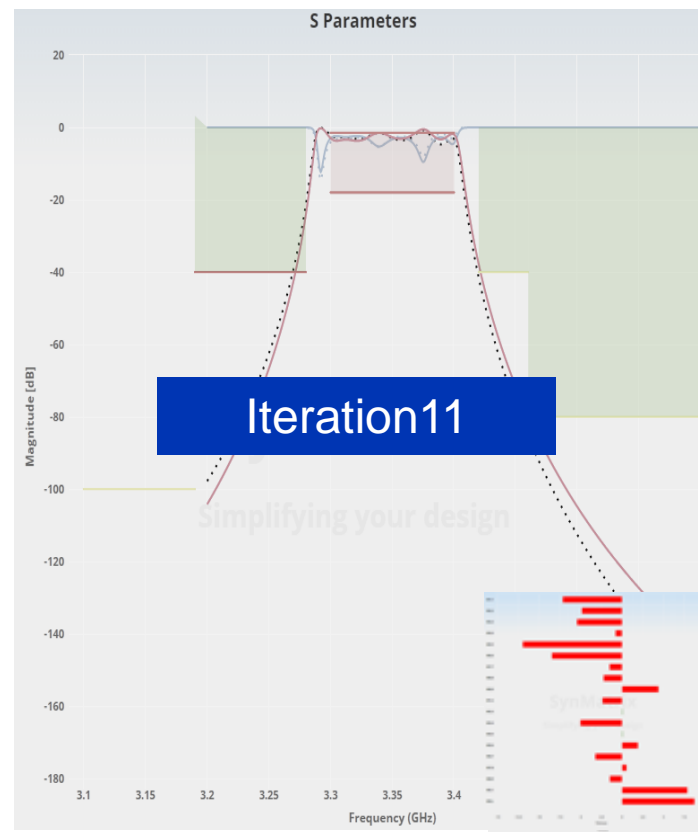
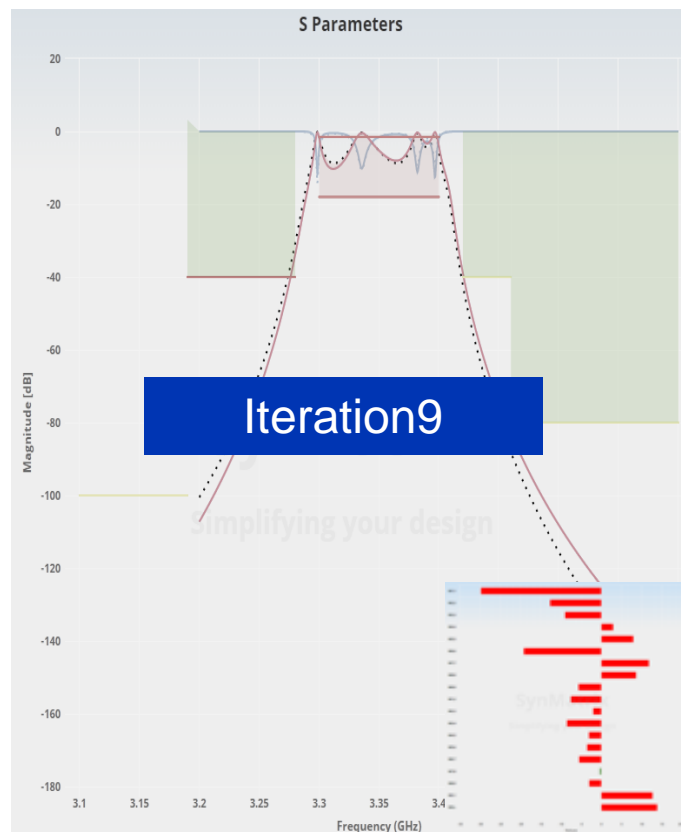

Step 4: 3D full EM wave simulation

Mapping the physical dimension to coupling matrix value – Start Tuning

1

Step 1: Start with chebyshev type filter

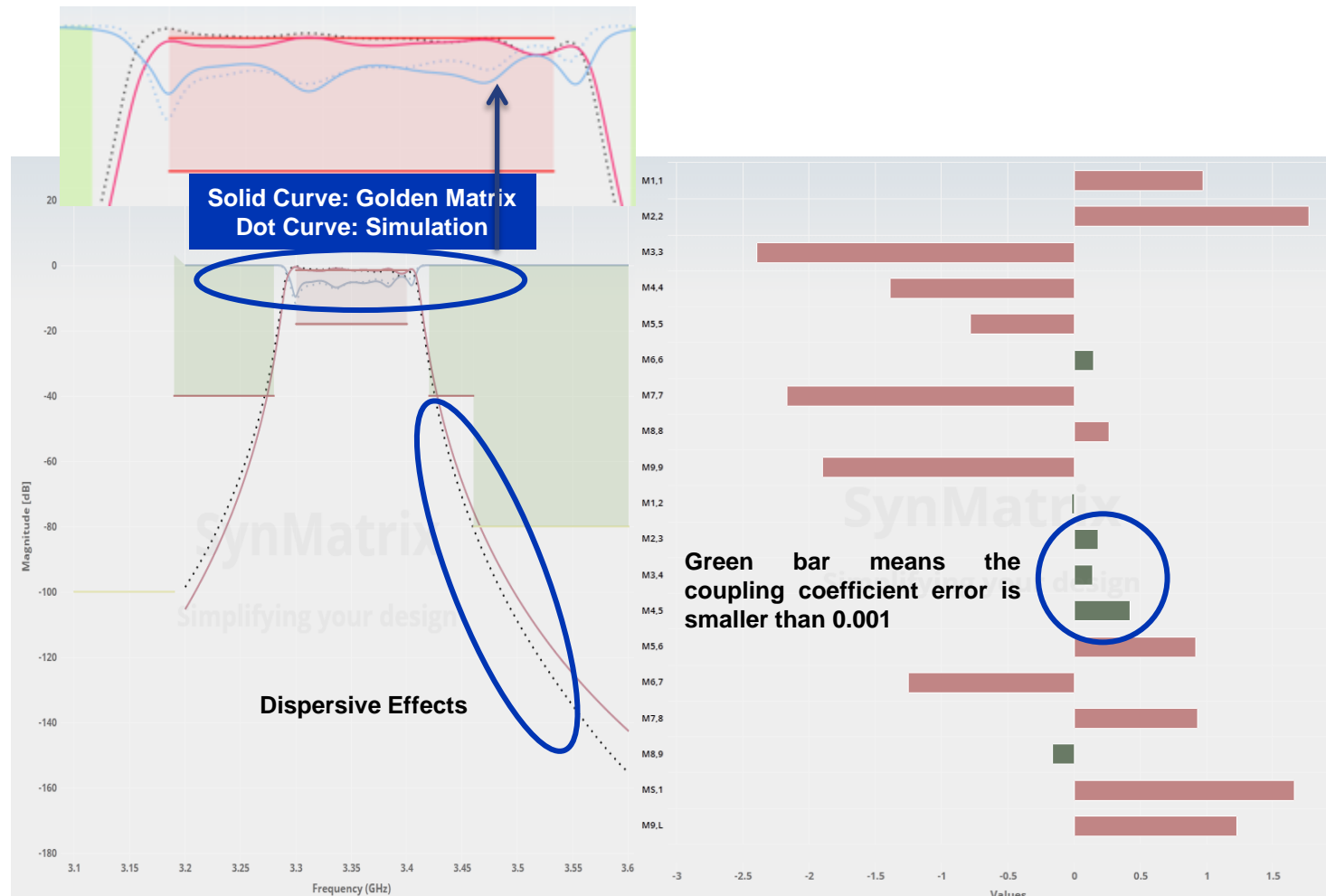

- After 20 iterated simulations, the errors decreased from maximum 450 to 3
- Due to the dispersive effective, the S21 at skirt area (out of the BW) cannot match with the golden matrix (target curve) very well
- In this stage, the user doesn't need to get perfect performance; Fine tuning work will be followed after the transmission zeros are added

Step 4: 3D full EM wave simulation

Add the first transmission zero

Step 2: Add the first transmission zero

2

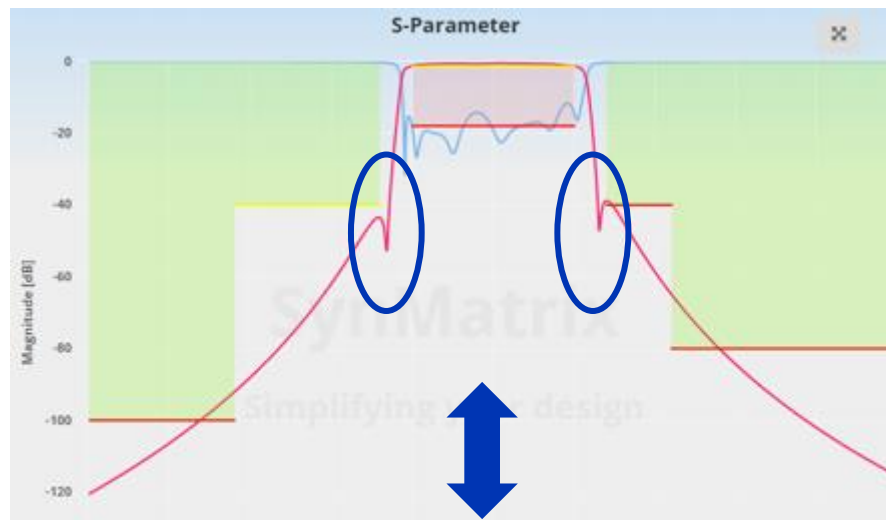
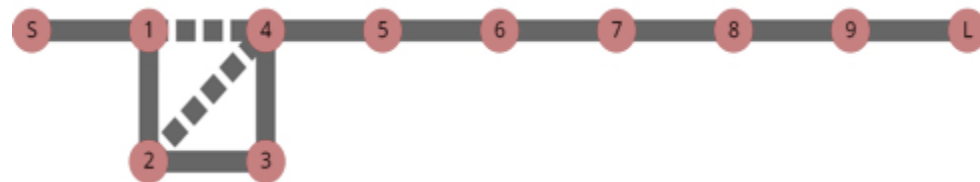

	S	1	2	3	4	5	6	7	8	9	L
S	0	1.0327	0	0	0	0	0	0	0	0	0
1	1.0327	0.0009	0.8131	0	-0.3686	0	0	0	0	0	0
2	0	0.8131	0.0171	0.8759	0.0180	0	0	0	0	0	0
3	0	0	0.8759	-0.0347	0.4924	0	0	0	0	0	0
4	0	-0.3686	0.0180	0.4924	0.0019	0.5778	0	0	0	0	0
5	0	0	0	0	0.5778	0.0035	0.5791	0	0	0	0
6	0	0	0	0	0	0.5791	0.0141	0.6266	0	0	0
7	0	0	0	0	0	0	0.6266	-0.1151	0.6367	0	0
8	0	0	0	0	0	0	0	0.6367	0.0010	0.8928	0
9	0	0	0	0	0	0	0	0	0.8928	0.0009	1.0327
L	0	0	0	0	0	0	0	0	0	1.0327	0

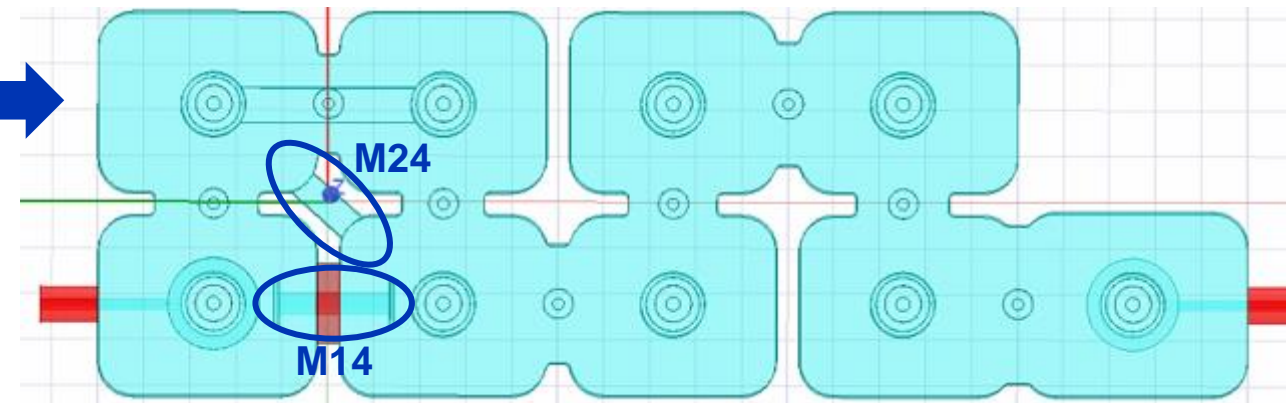

- Add the first transmission zero M14 and M24
- The negative sign for the cross coupling presents the electrical coupling, while the positive sign means magnetic coupling
- All previous well-tuned coupling values need to be fine-tuned again due to the cross-coupling addition, especially those close to the cross coupling area

Step 4: 3D full EM wave simulation

Add the first transmission zero

Step 2: Add the first transmission zero

2

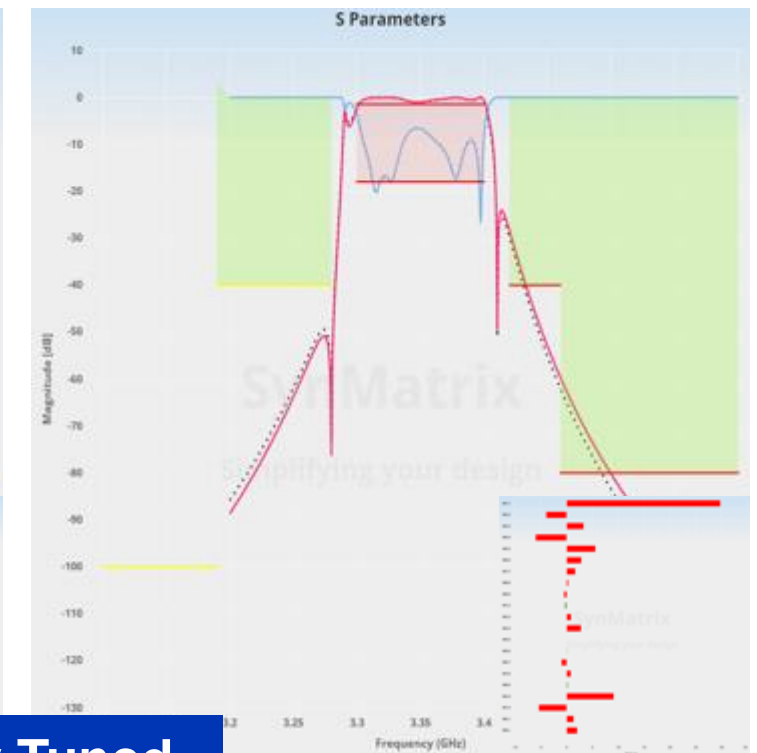
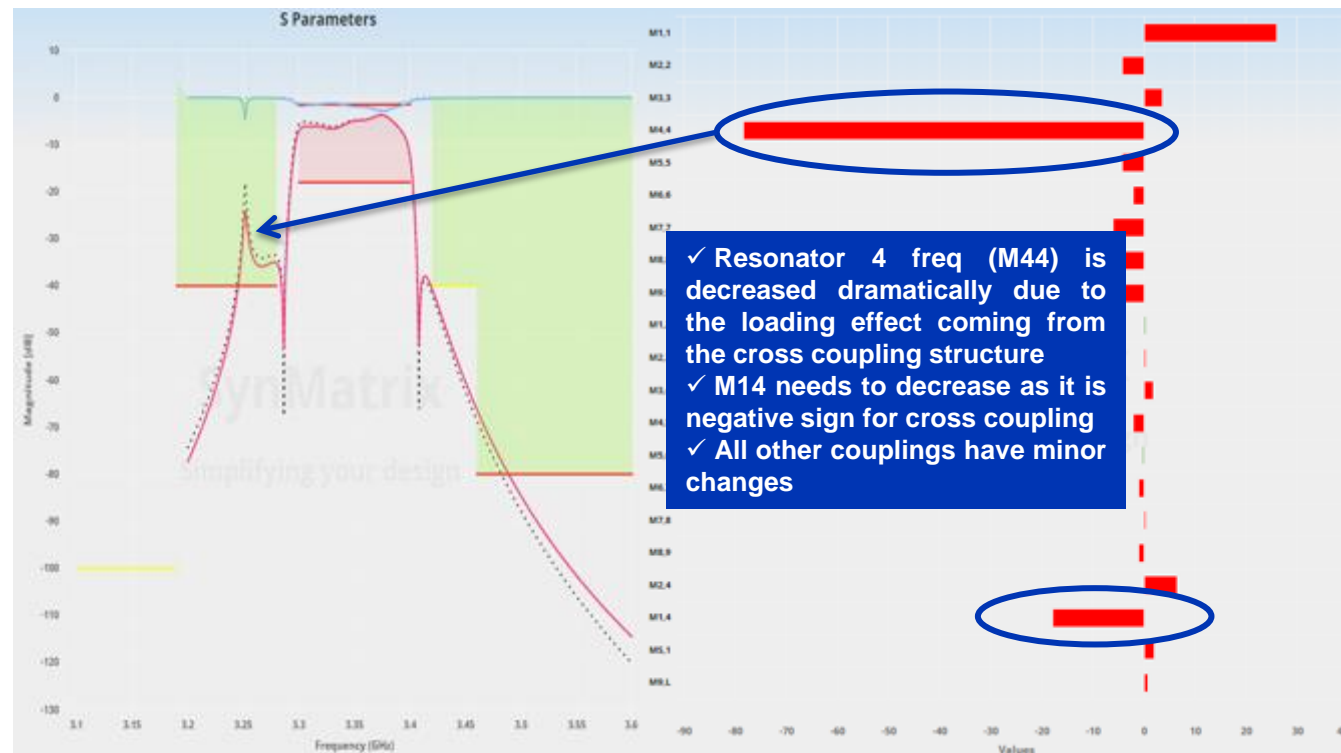
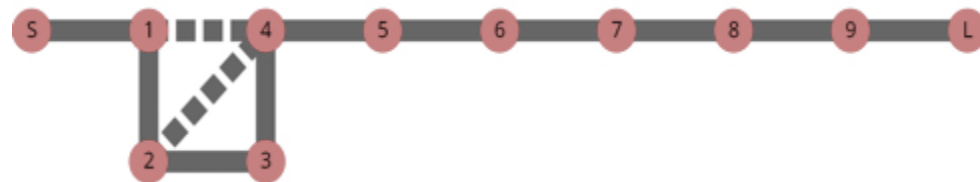

Stay Tuned

Step 4: 3D full EM wave simulation

Add the first transmission zero

Step 2: Add the first transmission zero

2

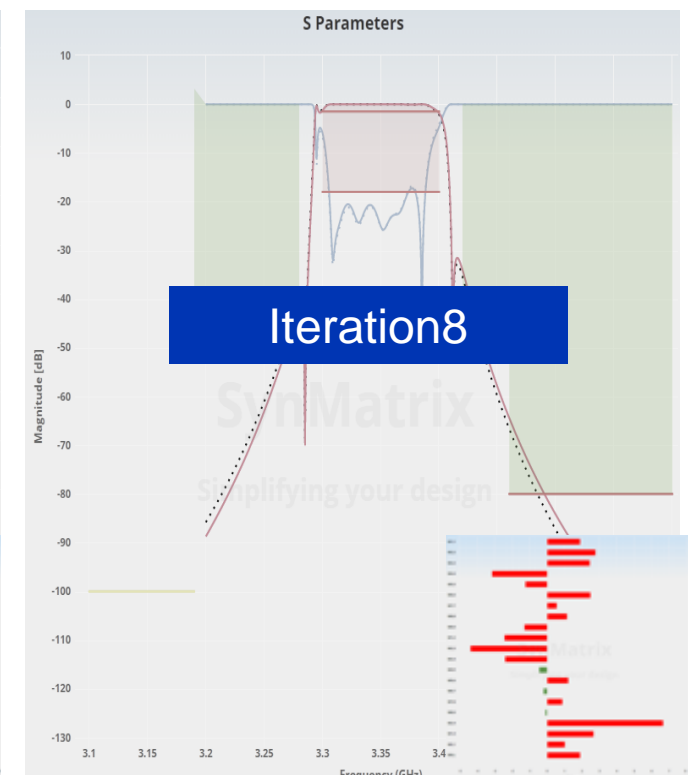
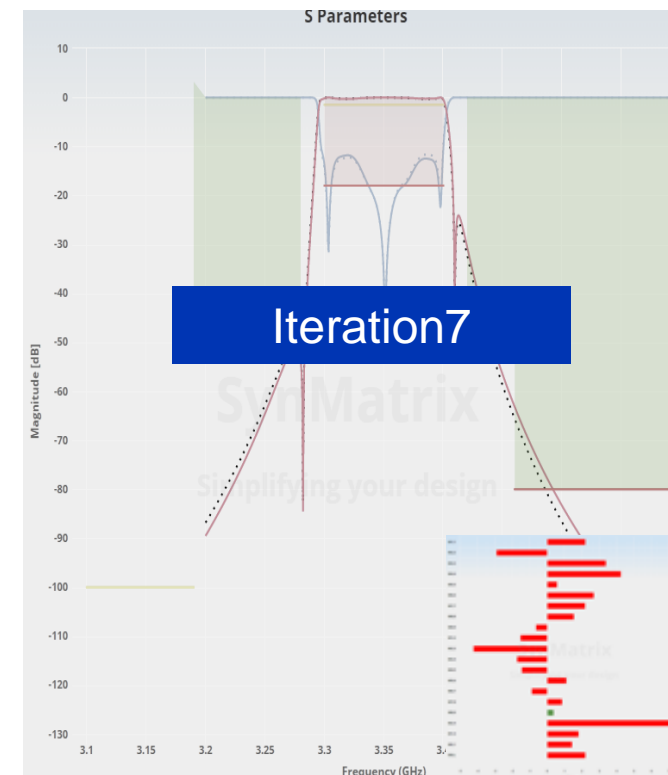
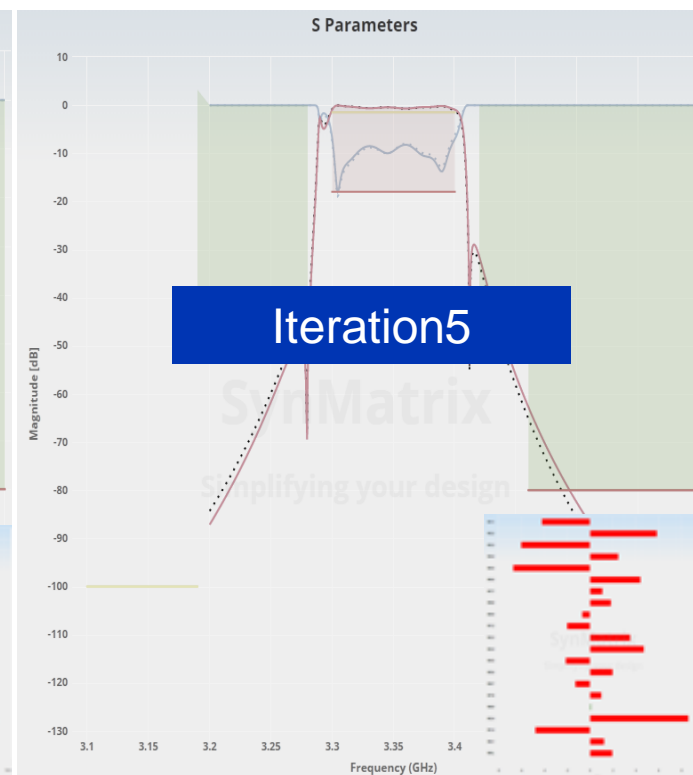
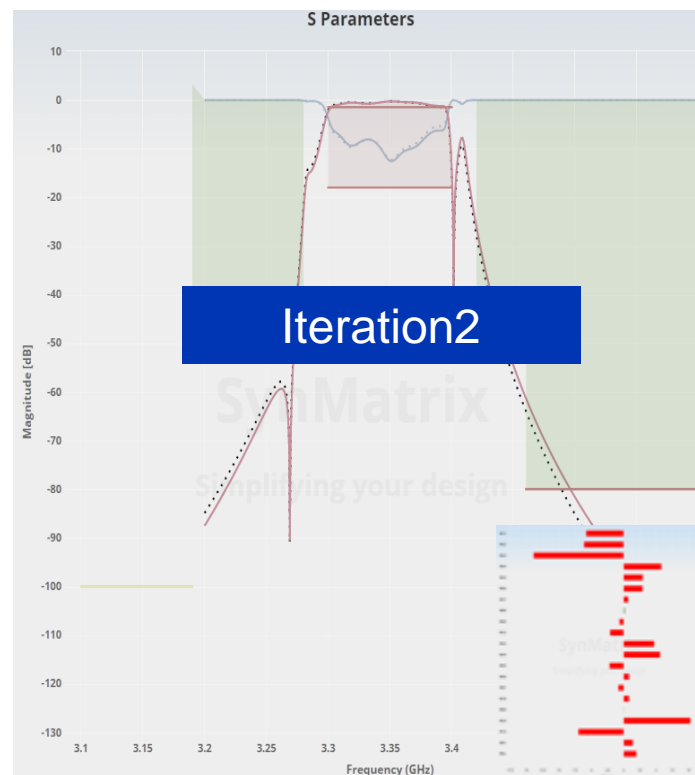
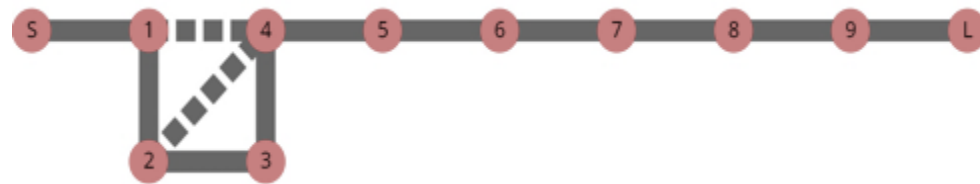

Step 4: 3D full EM wave simulation

Part 11 of 15

Add the first transmission zero

Step 2: Add the first transmission zero

2

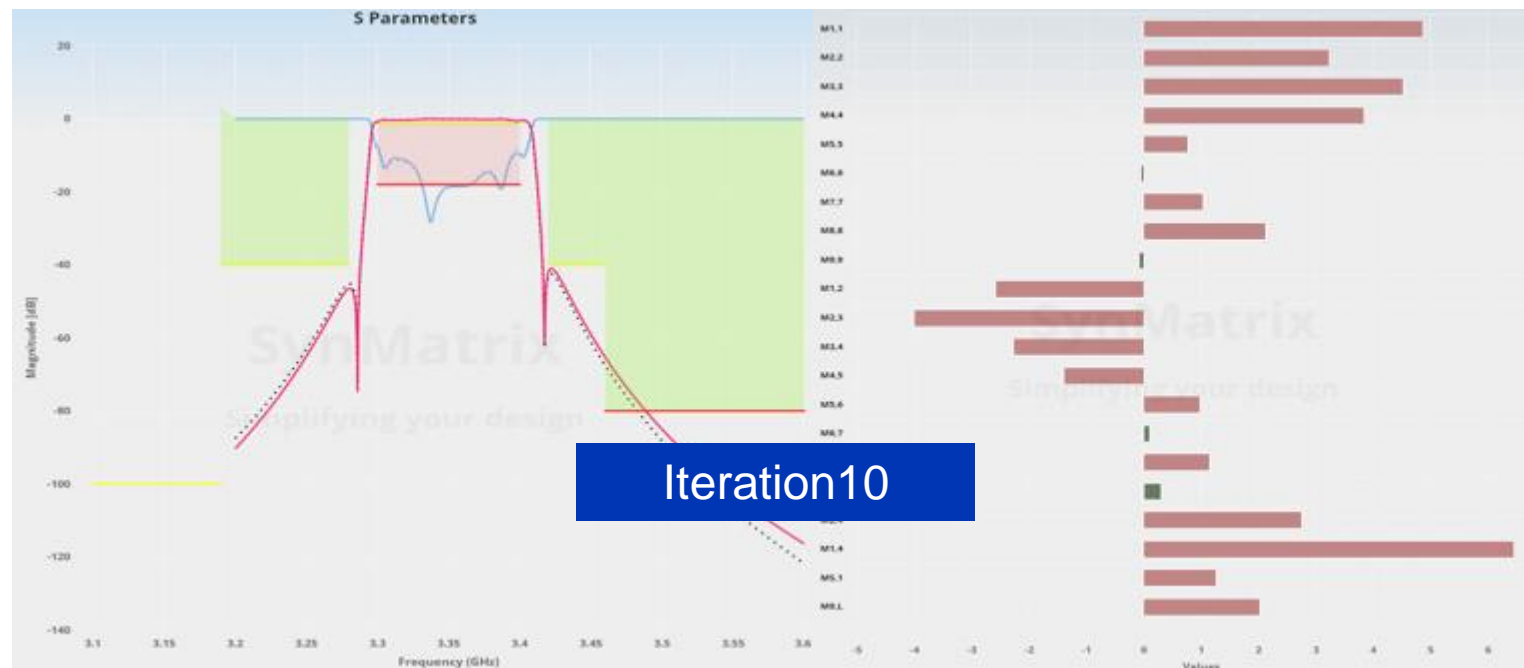
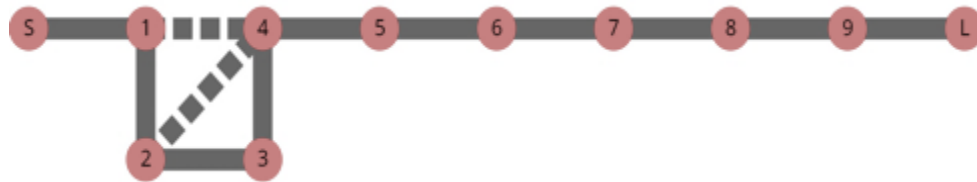

- Errors are decreasing from 90 to 8 on average
- Rule of thumb is to ensure the notch level is close to the golden matrix; the unperfected RL curve doesn't need to be the exact same as golden matrix
- Fine-tuning is not necessary in this step until two transmission zeros are added in the final stage

Step 4: 3D full EM wave simulation

The completed structure simulation

Step 3: The completed structure simulation

3

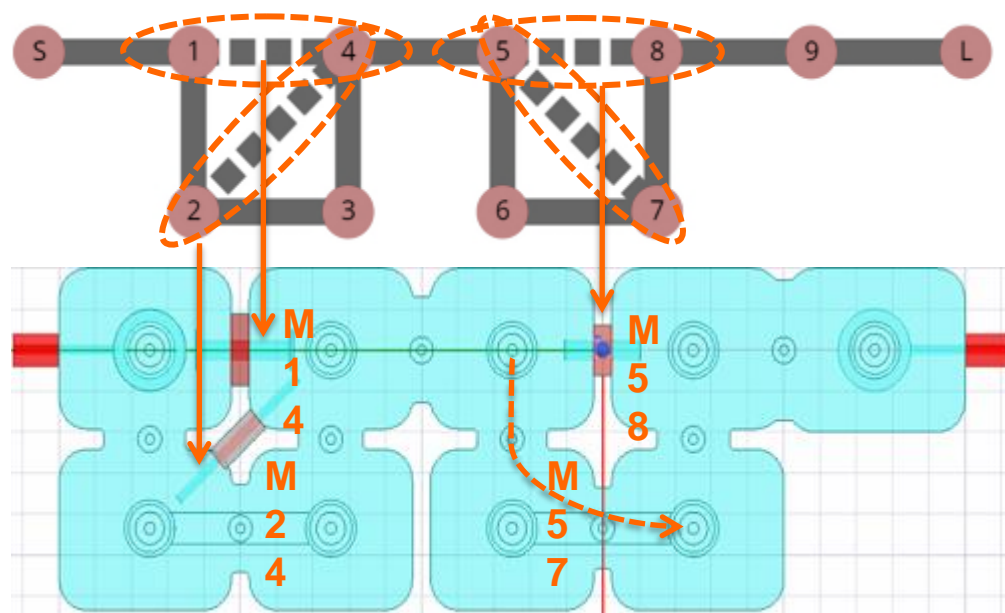

	S	1	2	3	4	5	6	7	8	9	L
S	0	1.0327	0	0	0	0	0	0	0	0	0
1	1.0327	0.0149	0.8131	0	-0.3686	0	0	0	0	0	0
2	0	0.8131	0.0311	0.8759	0.0180	0	0	0	0	0	0
3	0	0	0.8759	-0.0207	0.4924	0	0	0	0	0	0
4	0	-0.3686	0.0180	0.4924	0.0159	0.5778	0	0	0	0	0
5	0	0	0	0	0.5778	0.0175	0.5791	0	-0.0367	0	0
6	0	0	0	0	0	0.5791	0.0281	0.6266	0.0623	0	0
7	0	0	0	0	0	0	0.6266	-0.1011	0.6367	0	0
8	0	0	0	0	0	-0.0367	0.0623	0.6367	0.0150	0.8928	0
9	0	0	0	0	0	0	0	0	0.8928	0.0149	1.0327
L	0	0	0	0	0	0	0	0	0	1.0327	0

- M14:Negative Coupling
- M24:Positive Coupling. The structure is changed to negative coupling to compensate for the magnetic coupling by using the weak electrical coupling to balance the notch level
- M58:Negative coupling
- M57:Positive coupling. Since the second CQ (cascade quadruplet) structure has a very low notch level, which conducts very weak coupling energy, the stray coupling leaking from resonator 5 to resonator 7 will be used rather than building a physical structure

Step 4: 3D full EM wave simulation

The completed structure simulation

Step 3: The completed structure simulation

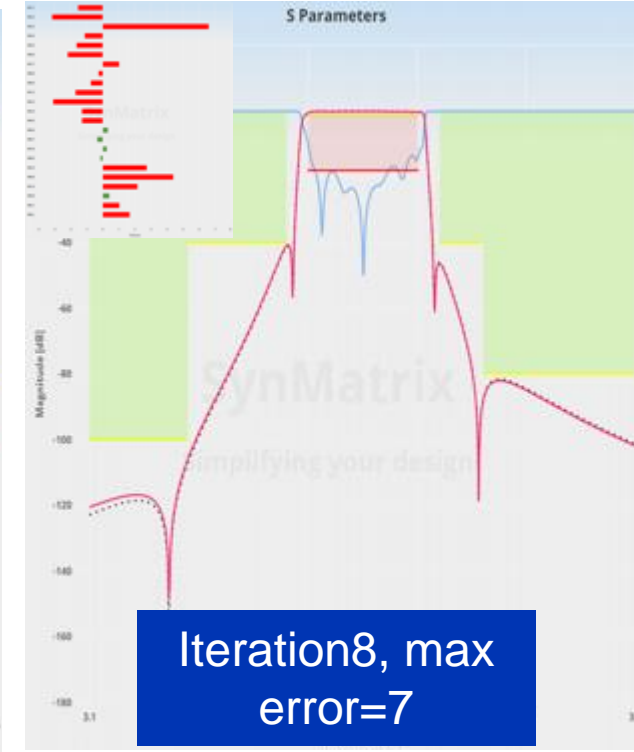
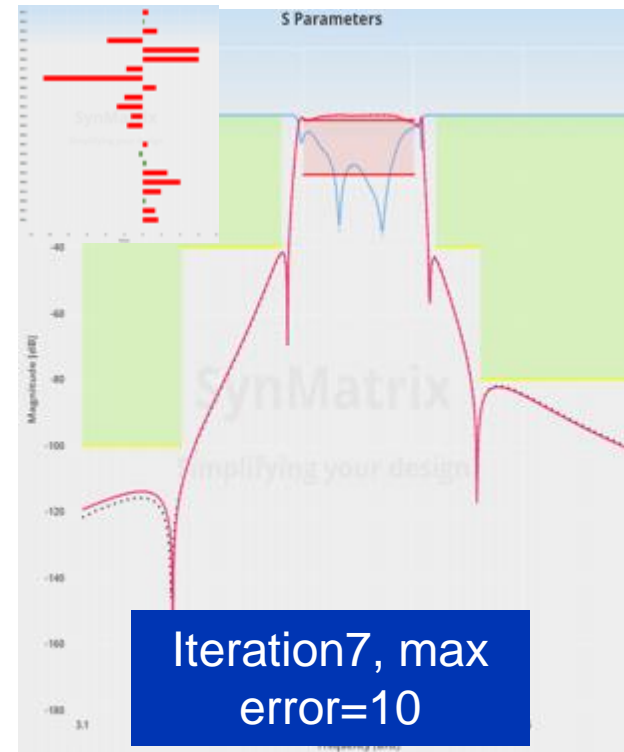
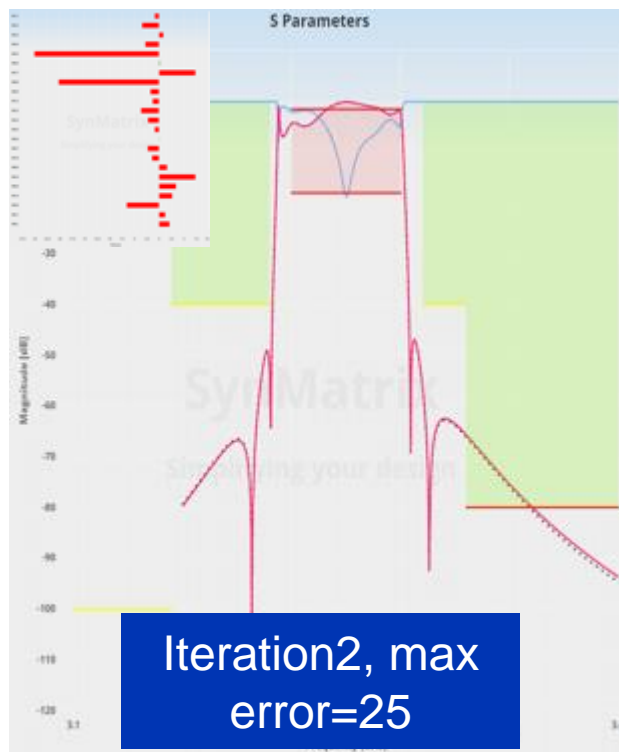
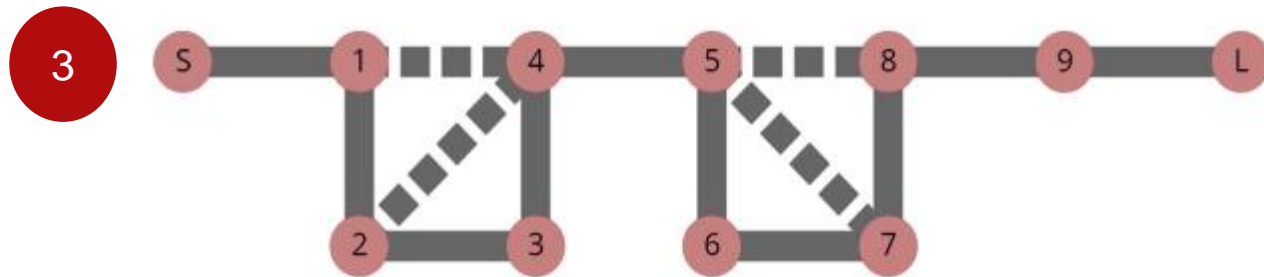

Step 4: 3D full EM wave simulation

The completed structure simulation

Step 3: The completed structure simulation

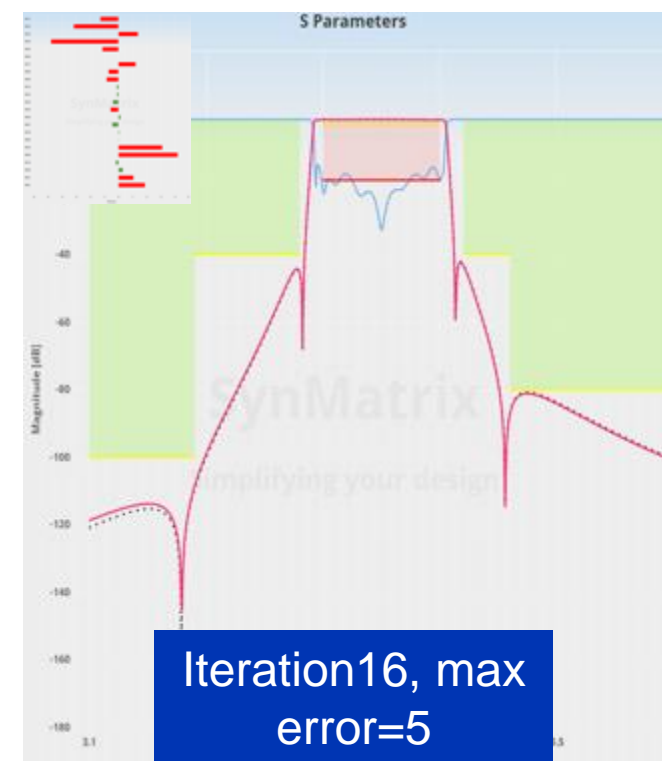
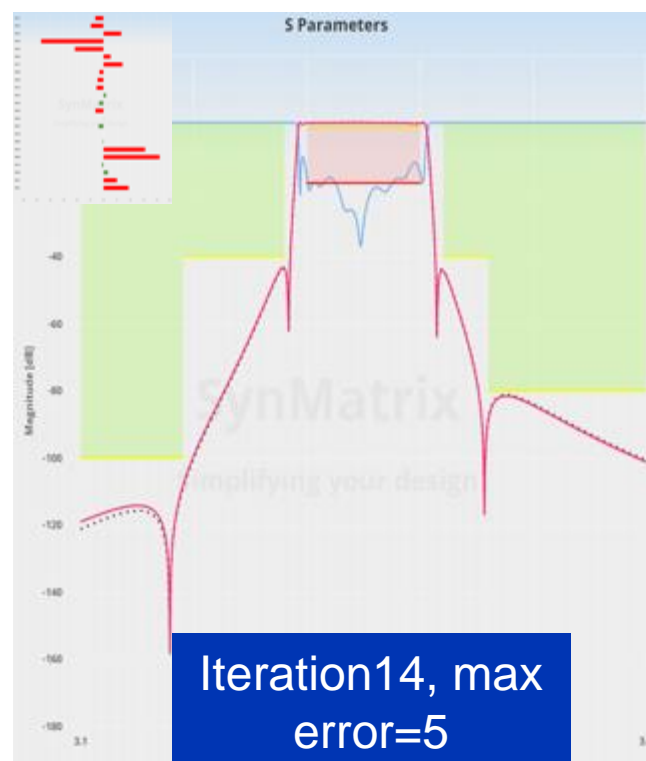
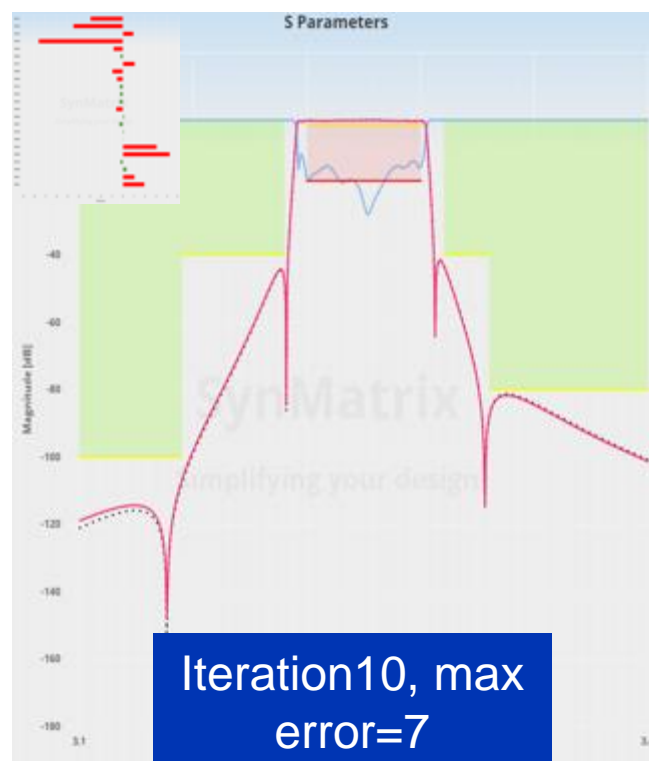
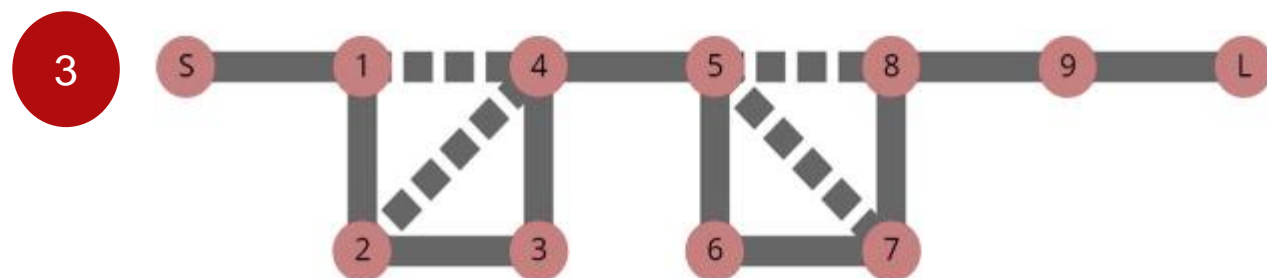

Step 4: 3D full EM wave simulation

The completed structure simulation

Step 3: The completed structure simulation

3

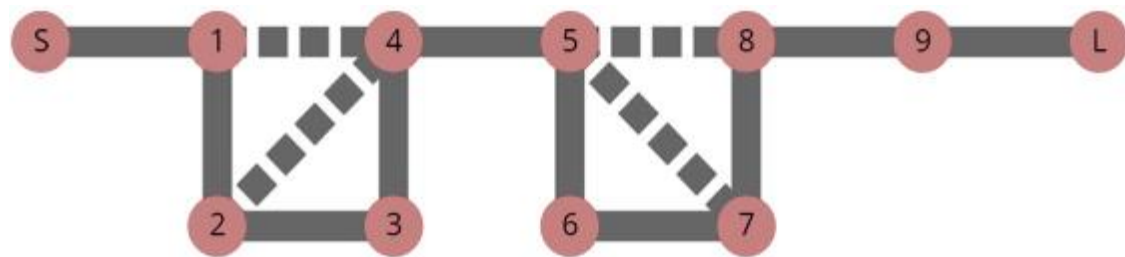

Name	Value	Unit	Evaluated
M1_1	0.158	in	0.158in
M2_2	0.157	in	0.157in
M3_3	0.1702	in	0.1702in
M4_4	0.1207	in	0.1207in
M5_5	0.1473	in	0.1473in
M6_6	0.1656	in	0.1656in
M7_7	0.1617	in	0.1617in
M8_8	0.1418	in	0.1418in
M9_9	0.1649	in	0.1649in
M1_2	0.17	in	0.17in
M2_3	0.205	in	0.205in

Dimension modify level <0.0003in

H_1	0.177	in	0.177in
H_0	0.177	in	0.177in
W1_2	0.45	in	0.45in
W2_3	0.43	in	0.43in
W3_4	0.355+0.0	in	0.355in
W4_5	0.515	in	0.515in
W5_6	0.385	in	0.385in
W6_7	0.393	in	0.393in
W7_8	0.4	in	0.4in
W8_9	0.688	in	0.688in
H_R1	0.62	in	0.62in
H_R9	0.62	in	0.62in

- ✓ All reflection poles (9 poles) are clear to see - coupling errors are extreme low
- ✓ Rejection level can meet the specification - Transmission Zeros can be controlled well
- ✓ Physical dimension changes in the range of 0.0003in is not achievable in reality; to save simulation time and resources, the simulation will be stopped at this stage
- ✓ The whole simulation can be completed within 4 hours (less than 30 iterations)

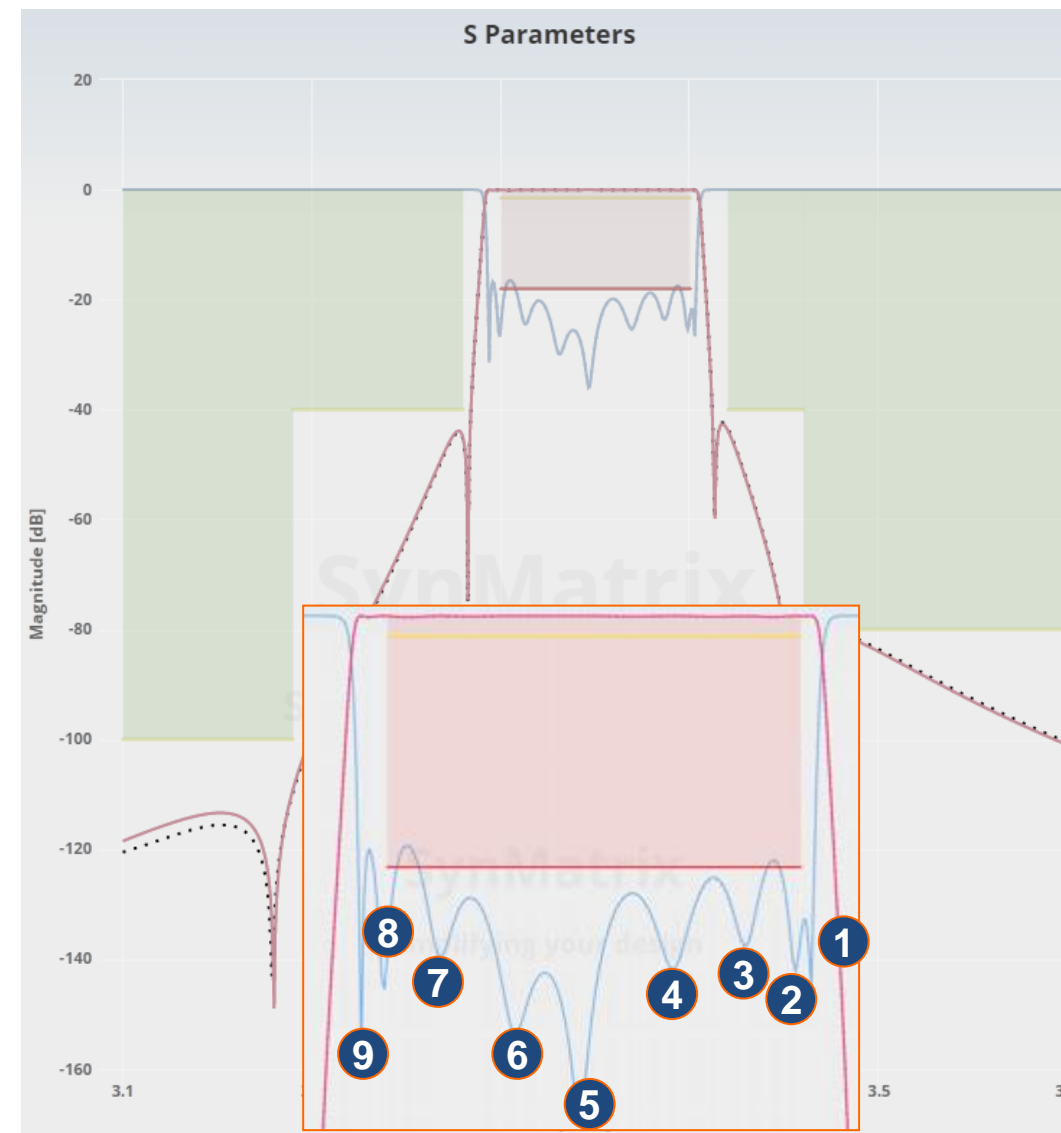

Use Case 2: AI-Optimized Design Platform

SYNMATRIX

Introducing a SynMatrix-HFSS integrated workflow for Microwave Filter Design.

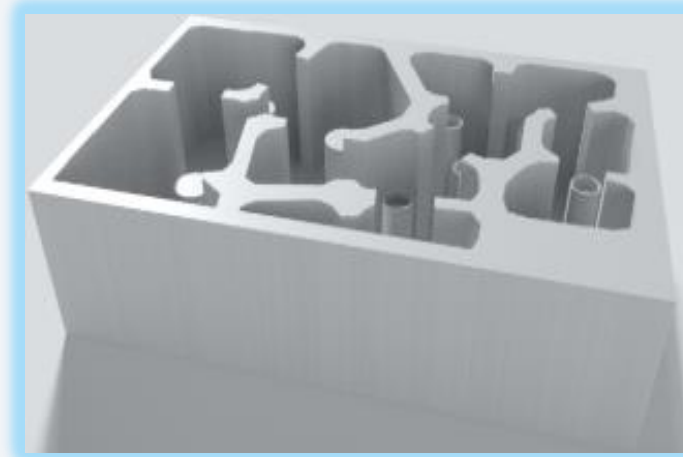

Use Case 2a: Coaxial Cavity Structure using Space Mapping method

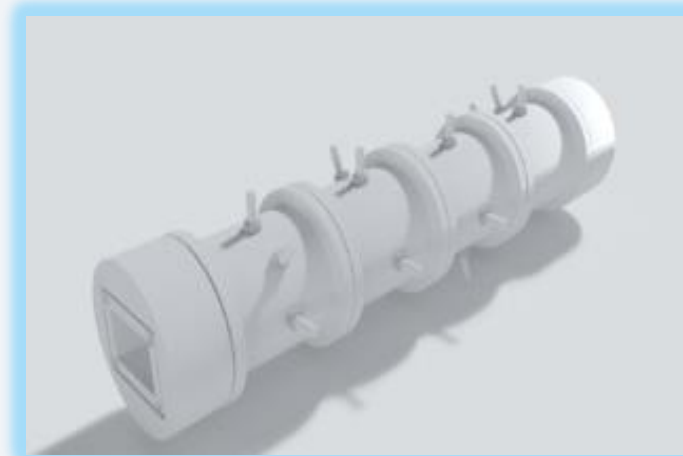

Use Case 2b: Waveguide Structure using AI-optimized method

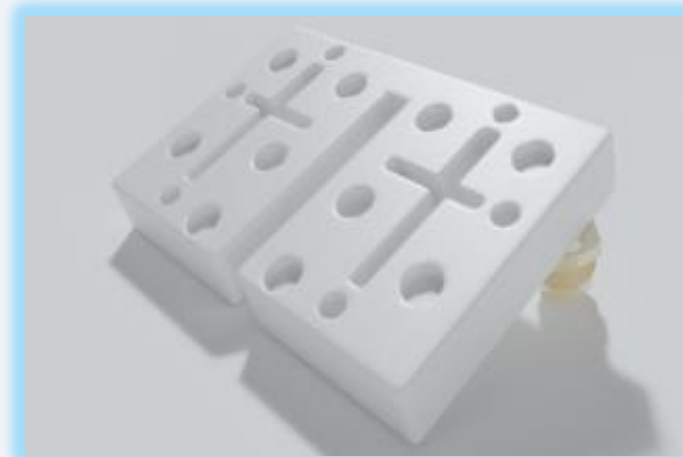

Use Case 2c: Dielectric Filled Waveguide using AI-optimized method

HFSS-integrated Workflow



Generate the
'Golden Matrix'

Dimension List	Status	Note	SIP File	Lower Bound	Last Result	Parameter Name	Updated Result	Upper Bound
0.125				0.125		M1,1 D11	0.25	0.375
0.15				0.15		M2,2 D12	0.3	0.45
0.18				0.18		M3,3 D13	0.35	0.525
0.21				0.21		M4,4 D14	0.42	0.63
0.24				0.24		M5,5 D15	0.48	0.72
0.27				0.27		M6,6 D16	0.54	0.81
0.3				0.3		M7,7 D17	0.6	0.9
0.33				0.33		M8,8 D18	0.66	0.99
0.36				0.36		M9,9 D19	0.72	1.08
0.39				0.39		M10,10 D20	0.78	1.17
0.42				0.42		M11,11 D21	0.84	1.26
0.45				0.45		M12,12 D22	0.9	1.35
0.48				0.48		M13,13 D23	0.96	1.44
0.51				0.51		M14,14 D24	1.02	1.53
0.54				0.54		M15,15 D25	1.08	1.62

Set-up simulation
and obtain initial
error



Preparation



Step 1



Step 2



Step 3

Load HFSS and
set up parameters

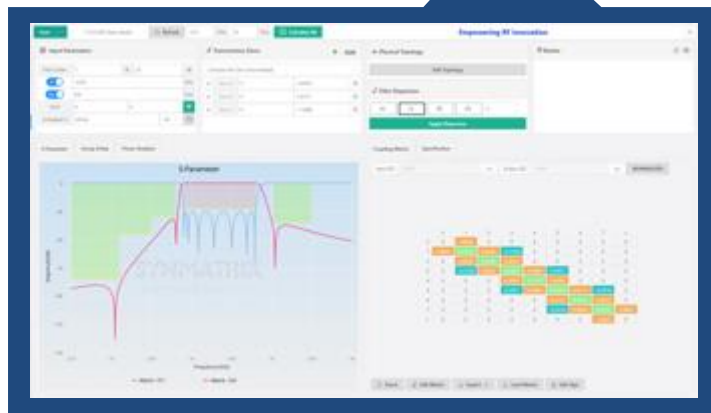

Run the
automated AI-
optimization
process



Use Case 2a: Space Mapping Method

Coaxial Cavity Structure

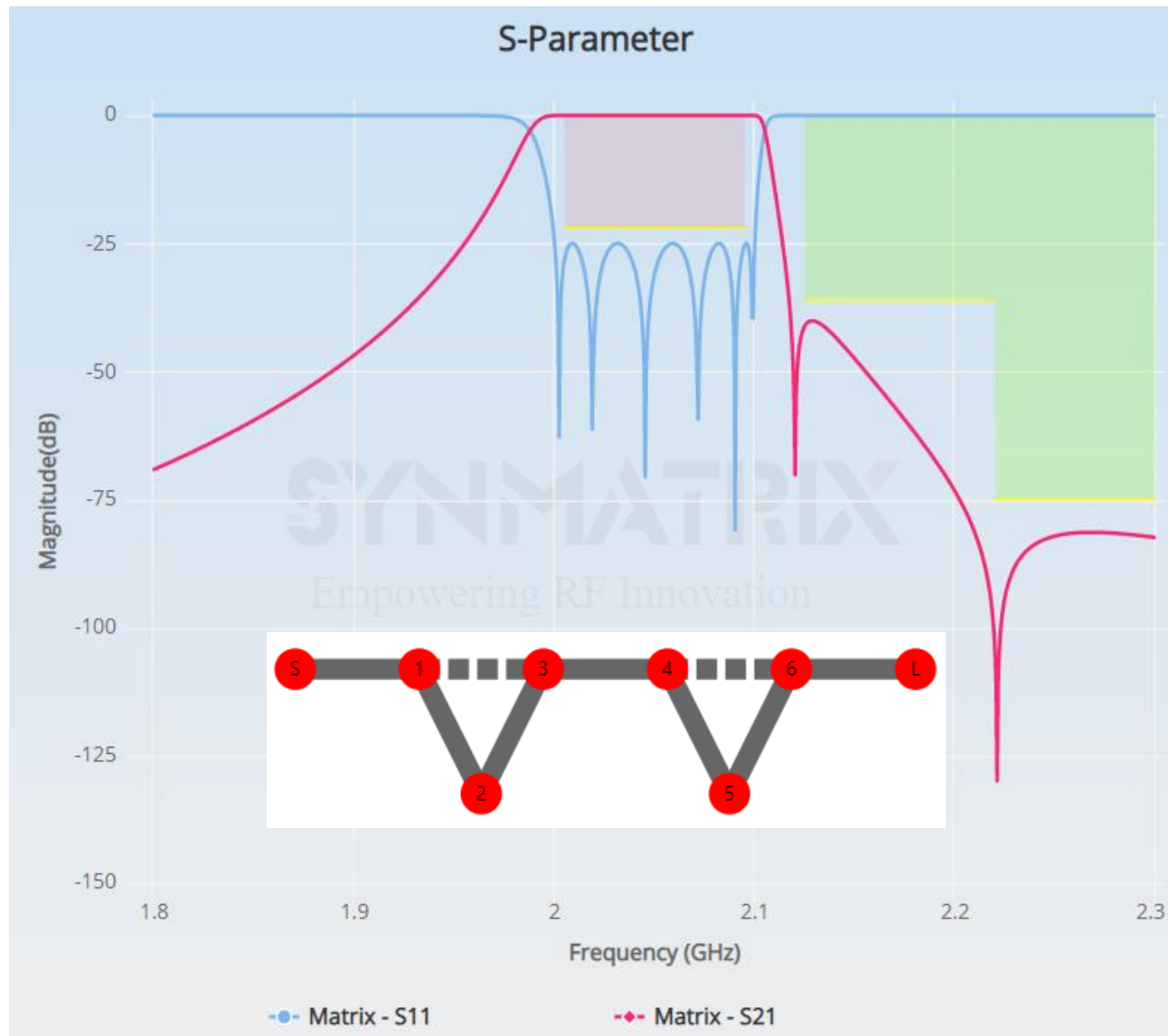

Design Spec: $f_0=2.25\text{GHz}$; $\text{BW}=0.1\text{GHz}$; $\text{RL}=22\text{dB}$;
 $T_{z1}= 2.12\text{GHz}$; $T_{z2}=2.22\text{GHz}$;

Structure: Coaxial cavity **Optimizer:** Automatic Space Mapping
Computer Specification: CPU: Inter Xeon E5-1620@3.6GHz
 Memory: 16Ghz

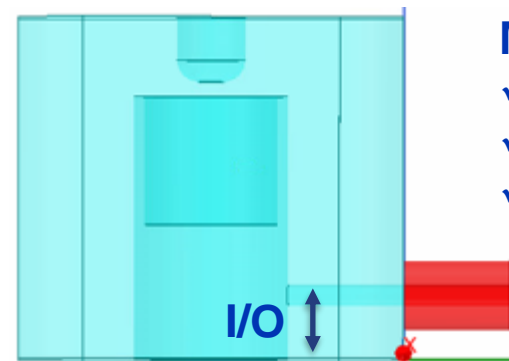

Mapping Rules

- ✓ I/O: Height of tab
- ✓ Freq: Depth of screw
- ✓ Coupling: Depth of screw

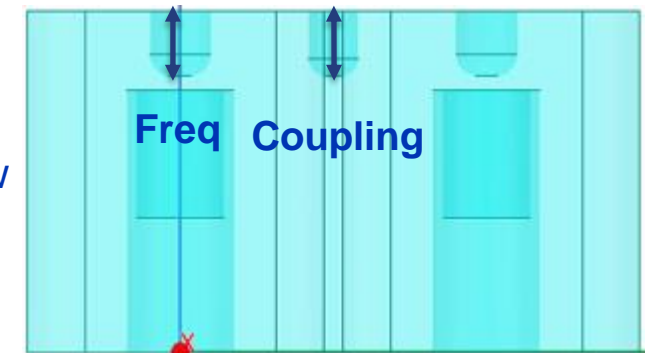

	S	1	2	3	4	5	6	L
S	0	1.1028	0	0	0	0	0	0
1	1.1028	0.0332	0.7797	0.5239	0	0	0	0
2	0	0.7797	-0.6593	0.4913	0	0	0	0
3	0	0.5239	0.4913	0.1327	0.6129	0	0	0
4	0	0	0	0.6129	0.0958	0.6270	0.1871	0
5	0	0	0	0	0.6270	-0.2152	0.9206	0
6	0	0	0	0	0.1871	0.9206	0.0332	1.1028
L	0	0	0	0	0	0	1.1028	0

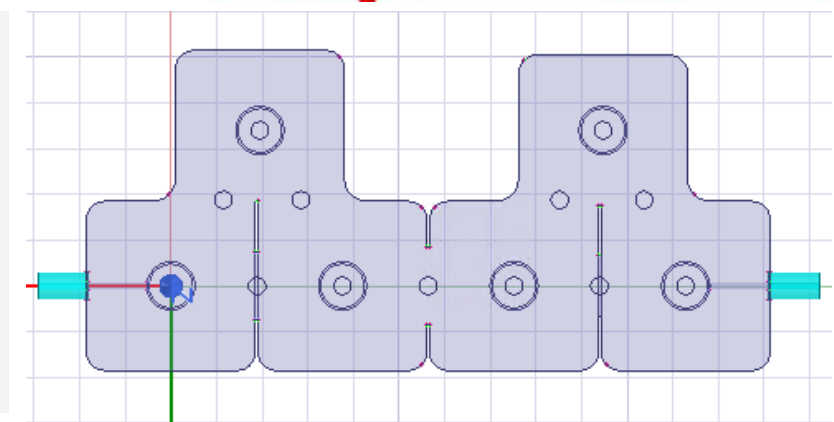

Use Case 2a: Space Mapping Method

Coaxial Cavity Structure

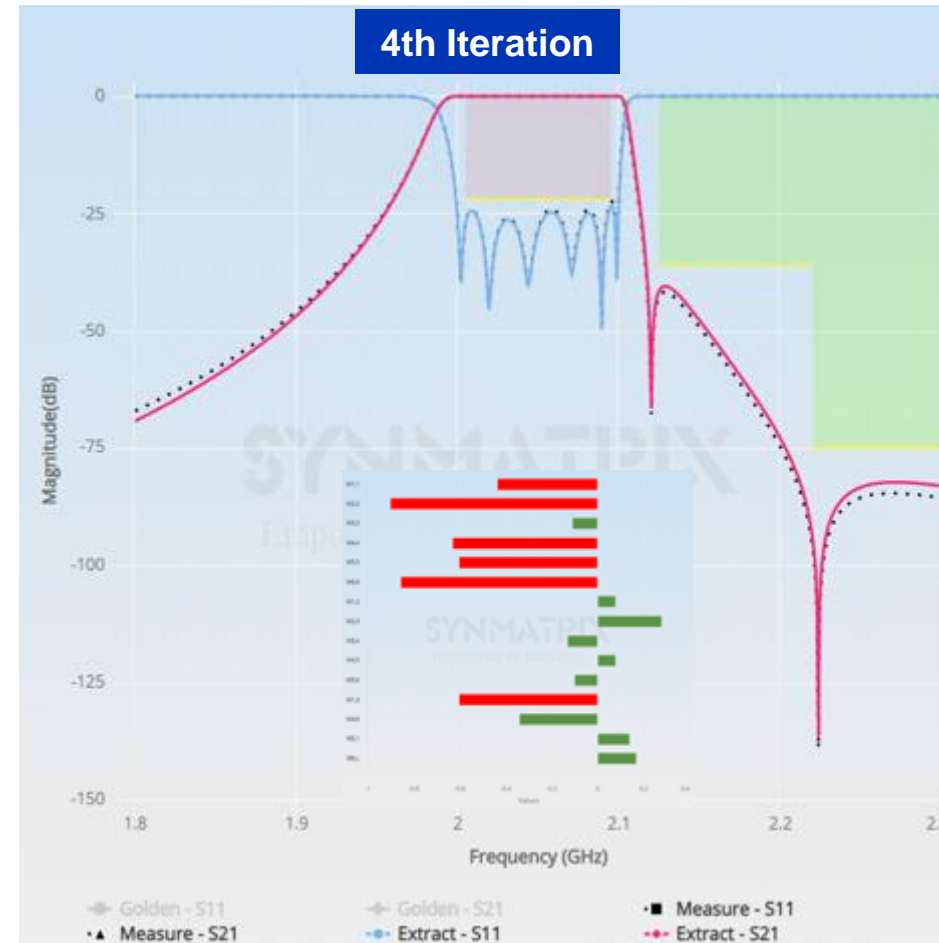
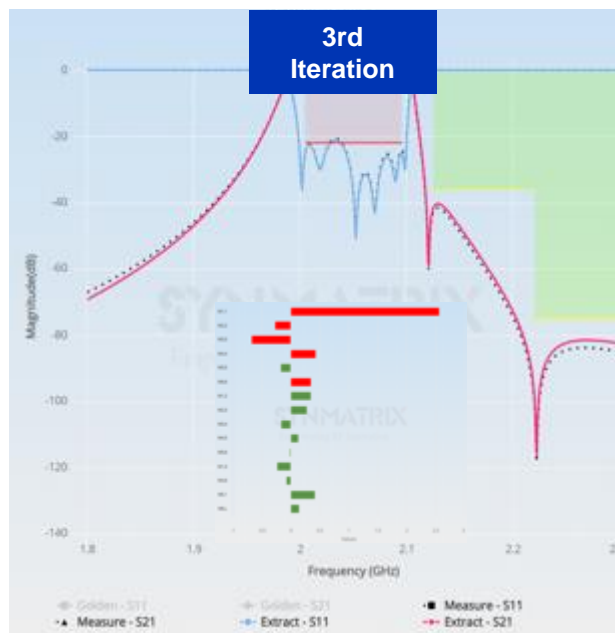
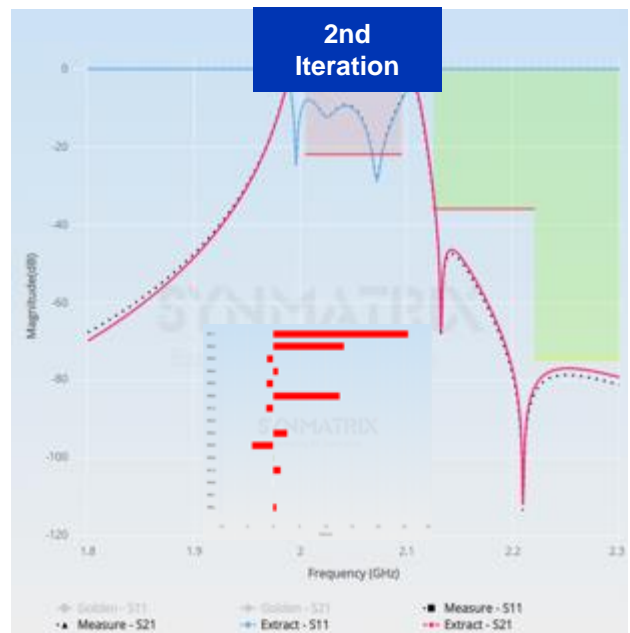
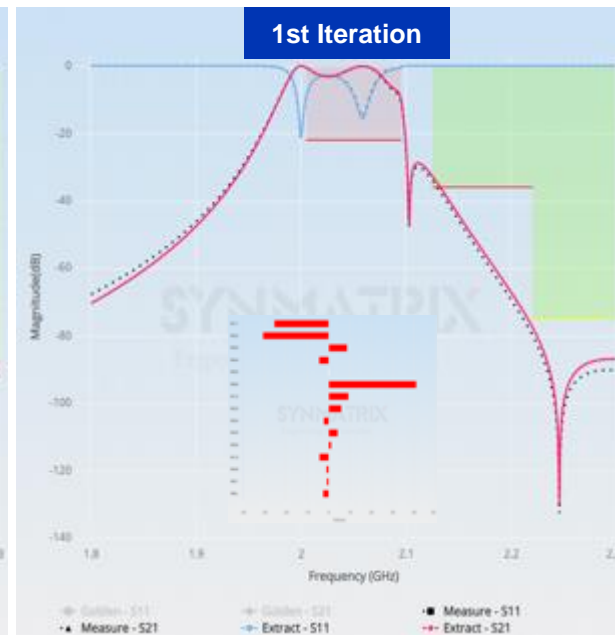
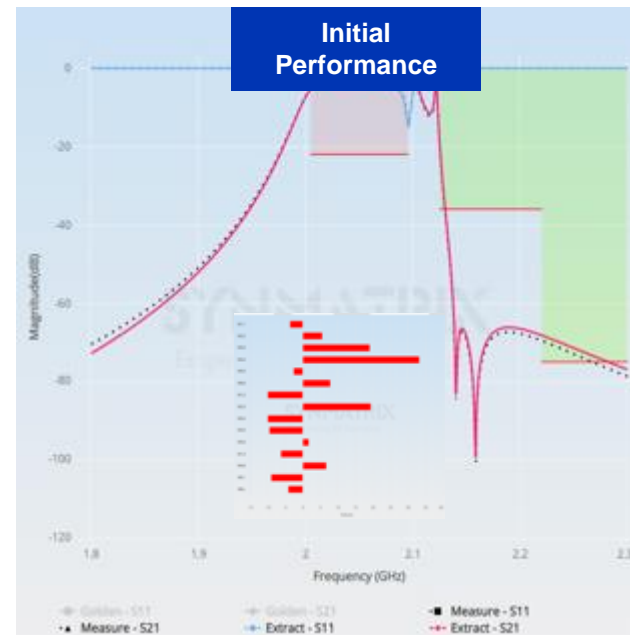

Total simulation: 1Hr 45mins

- 8 iteration passes
- 801 points
- 5mins for each simulation

Use Case 2b: AI Method

Waveguide Structure

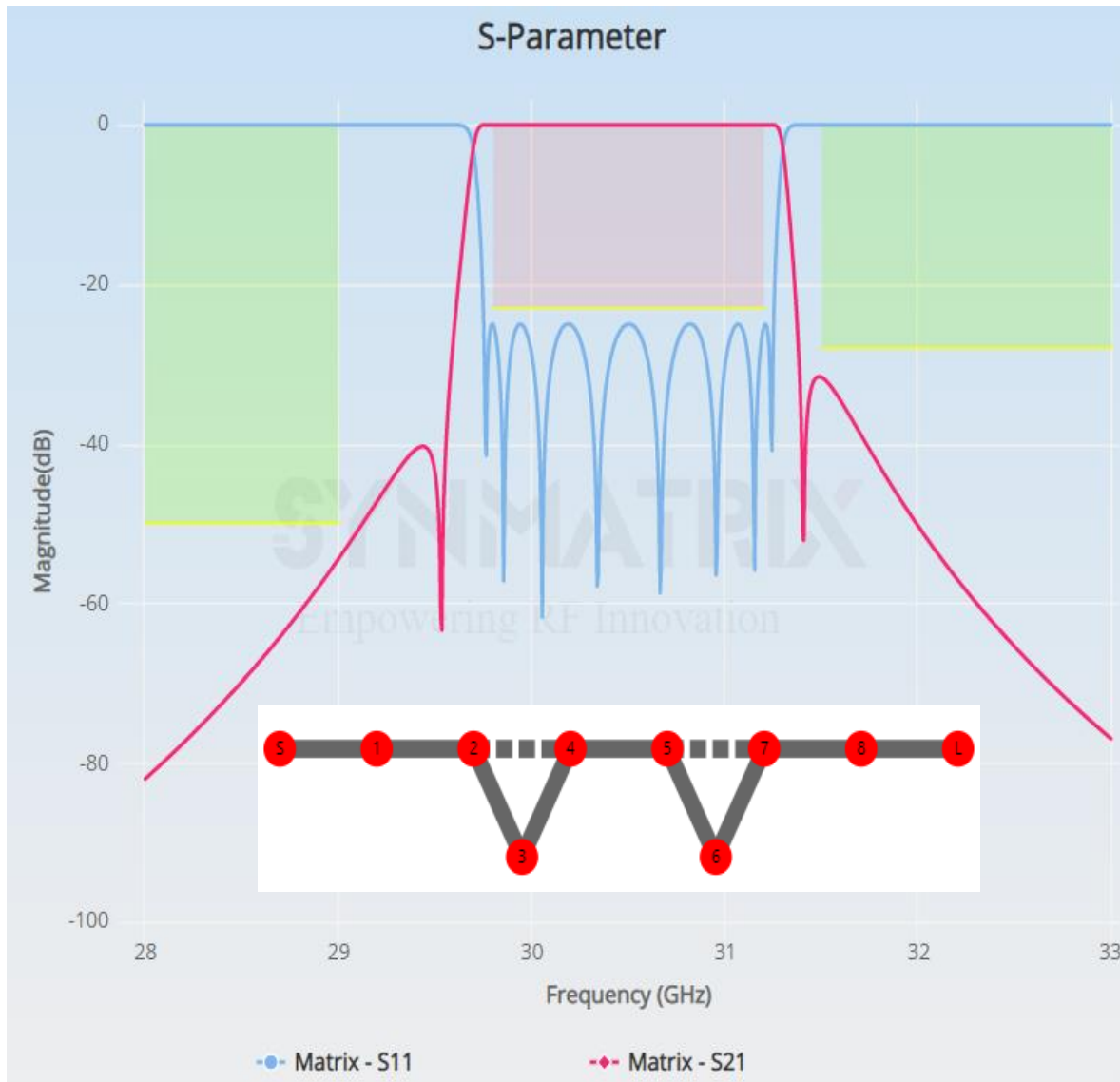

Design Spec: $f_0=30.5\text{GHz}$; $\text{BW}=1.5\text{GHz}$; $\text{RL}=23\text{dB}$;
 $\text{Tz}_1=29.54\text{GHz}$; $\text{Tz}_2=31.41\text{GHz}$;

Structure: Rectangular Waveguide(WR-622);

Optimizer: AI Optimizer + Dispersive effect control

Mapping Rules:

- ✓ Freq: Waveguide Length
- ✓ I/O: Iris Width
- ✓ Coupling: Iris Width

	S	1	2	3	4	5	6	7	8	L
S	0	1.0806	0	0	0	0	0	0	0	0
1	1.0806	0.0022	0.8985	0	0	0	0	0	0	0
2	0	0.8985	0.0024	0.5082	-0.3403	0	0	0	0	0
3	0	0	0.5082	0.6206	0.4550	0	0	0	0	0
4	0	0	-0.3403	0.4550	-0.0161	0.5545	0	0	0	0
5	0	0	0	0	0.5545	0.0252	0.4137	0.3928	0	0
6	0	0	0	0	0	0.4137	-0.7062	0.4688	0	0
7	0	0	0	0	0	0.3928	0.4688	0.0024	0.8985	0
8	0	0	0	0	0	0	0	0.8985	0.0022	1.0806
L	0	0	0	0	0	0	0	0	1.0806	0

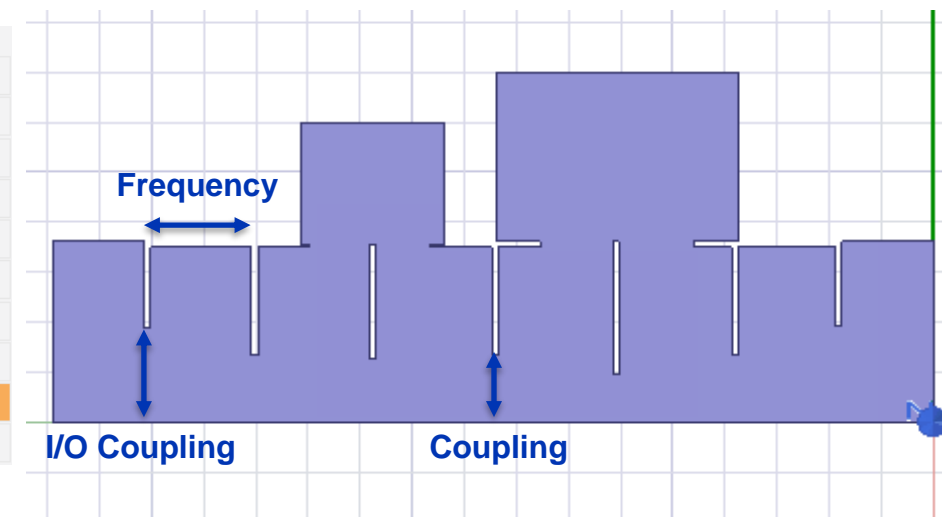

Use Case 2b: AI Method

Waveguide Structure

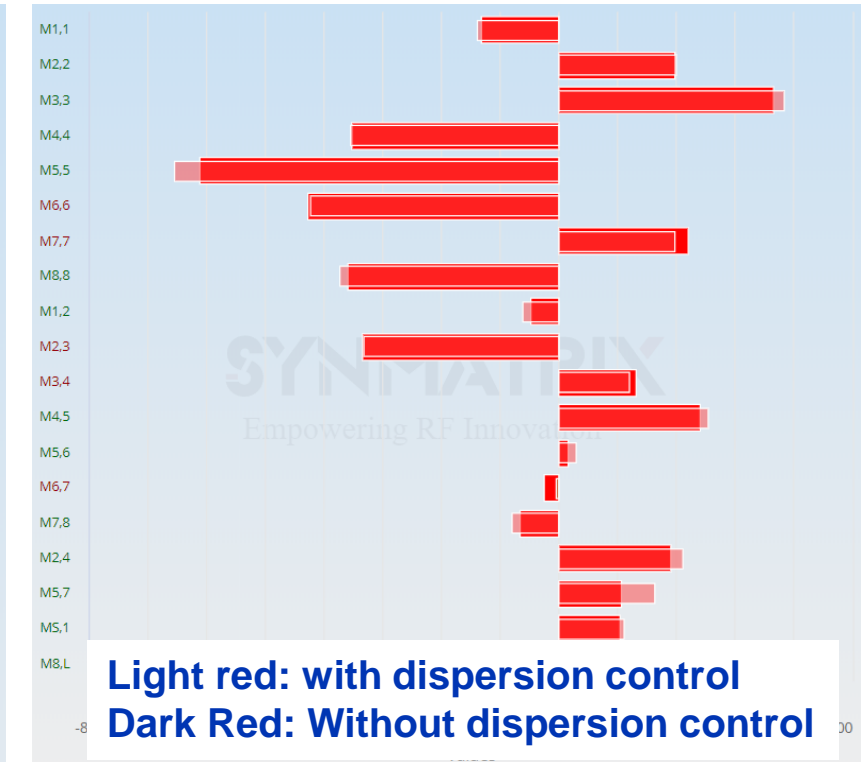
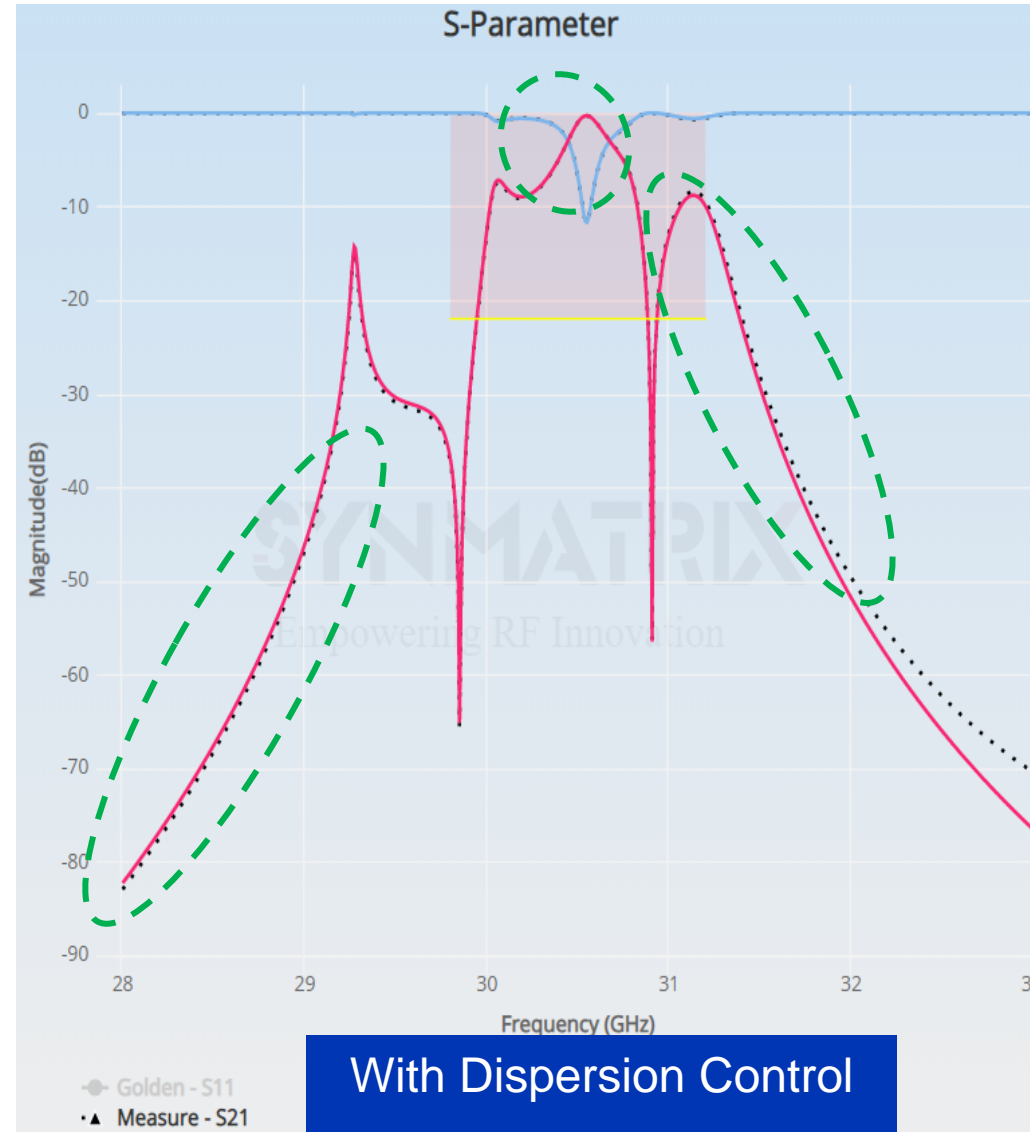
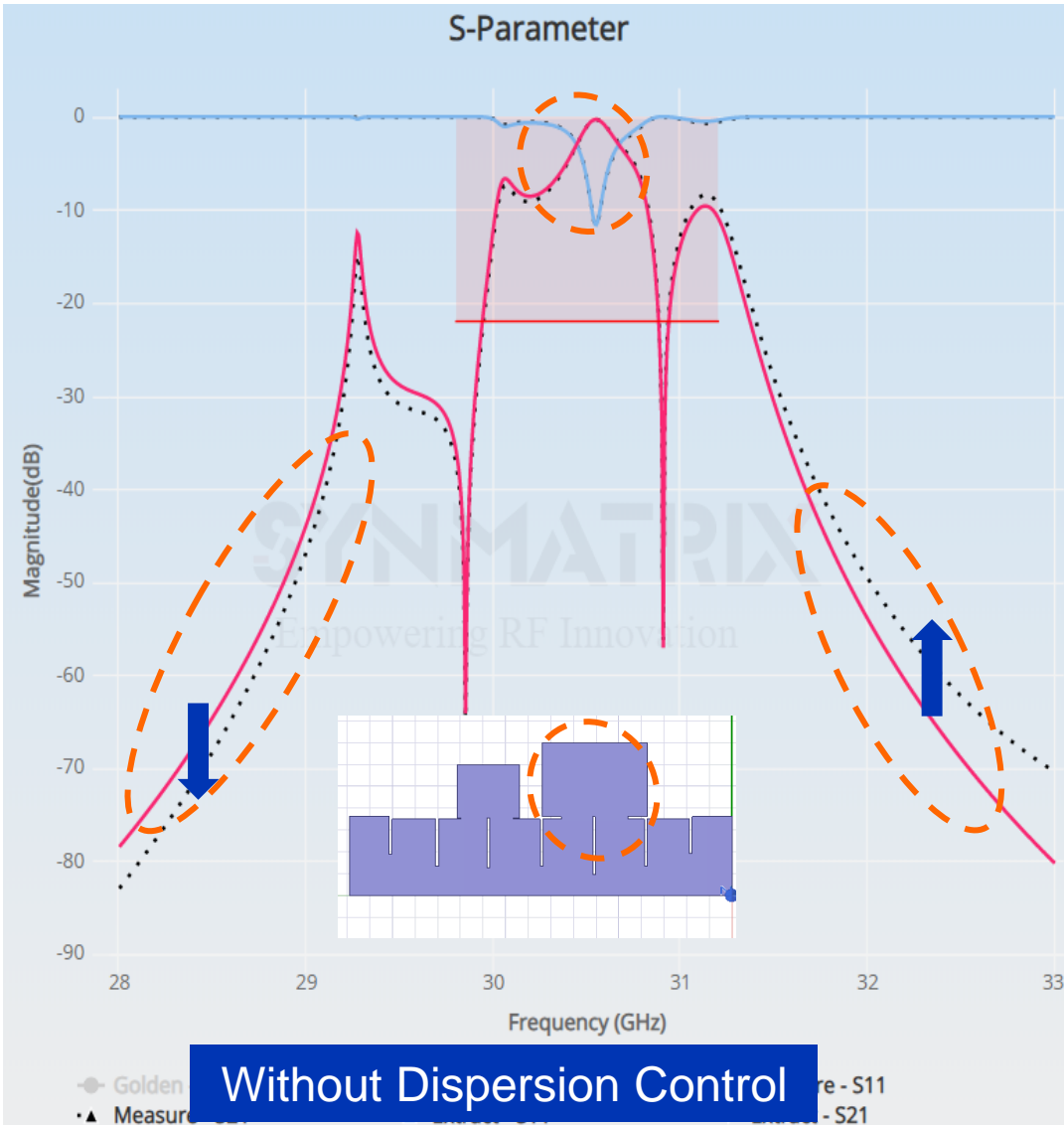

✓ With dispersion control, the matrix extraction accuracy will increase about 2~5%. These minor changes are very critical when RL is lower than 20dB

Use Case 2b: AI Method

Waveguide Structure

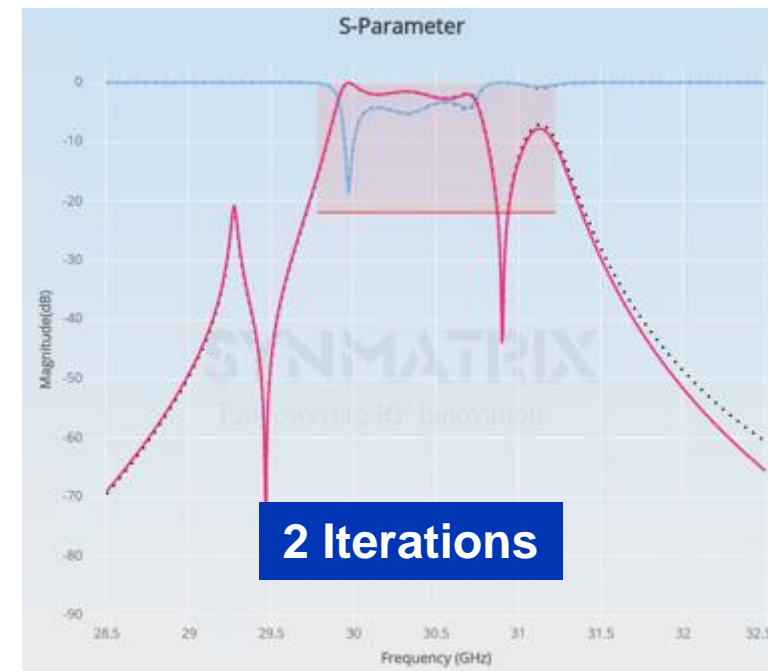

2 Iterations

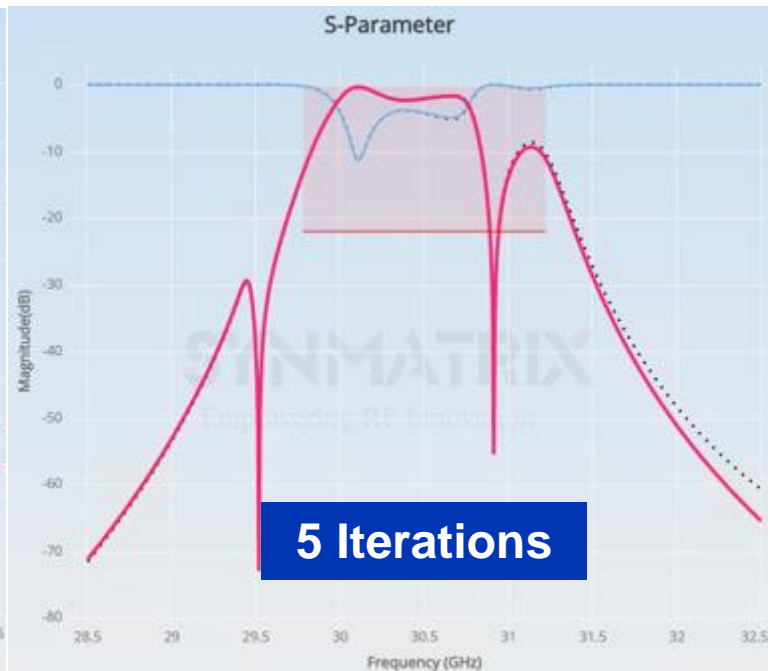

5 Iterations

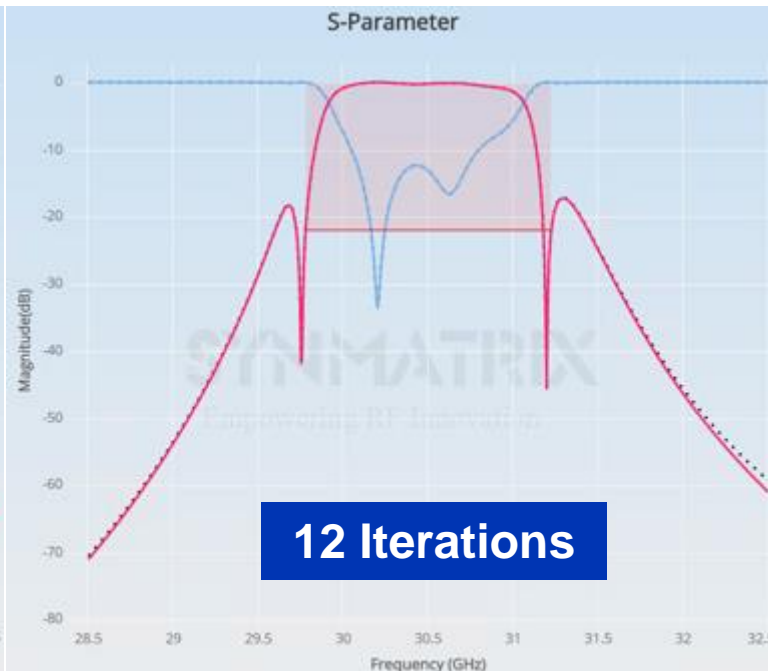

12 Iterations

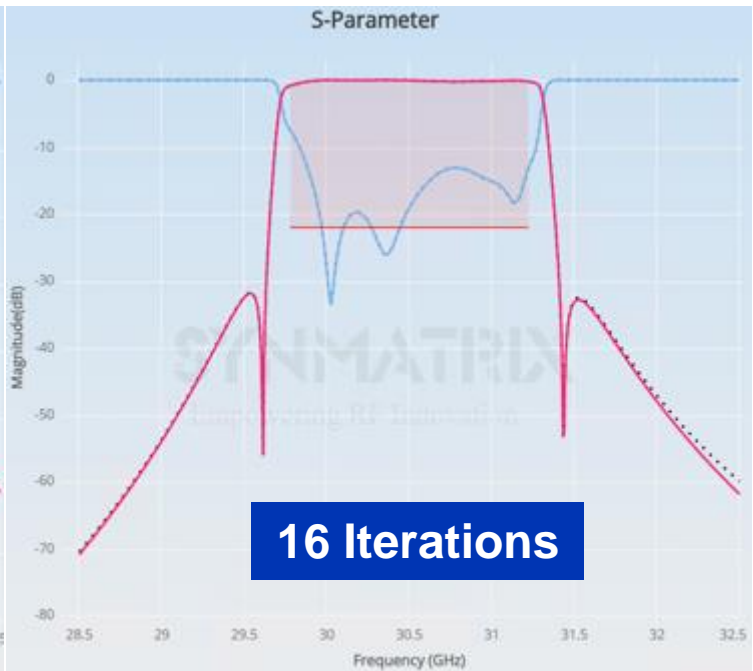

16 Iterations

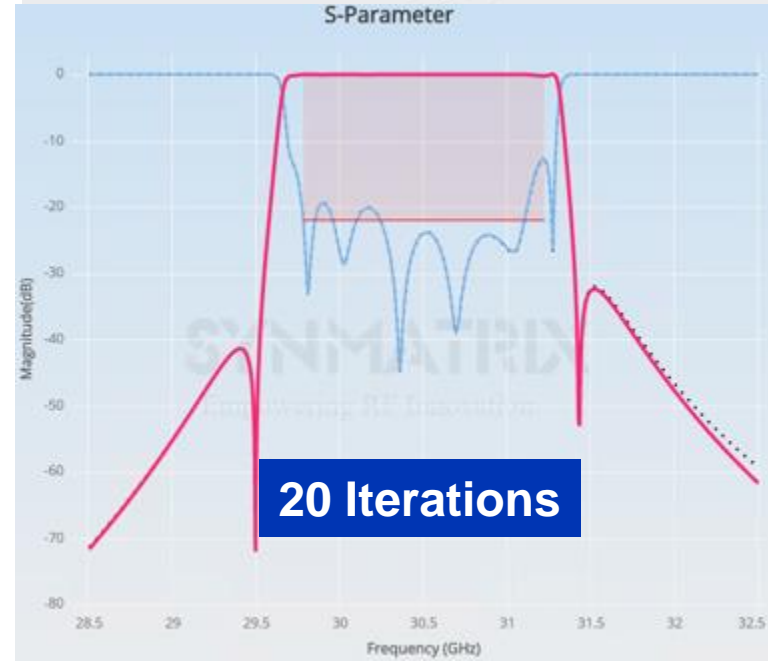

20 Iterations

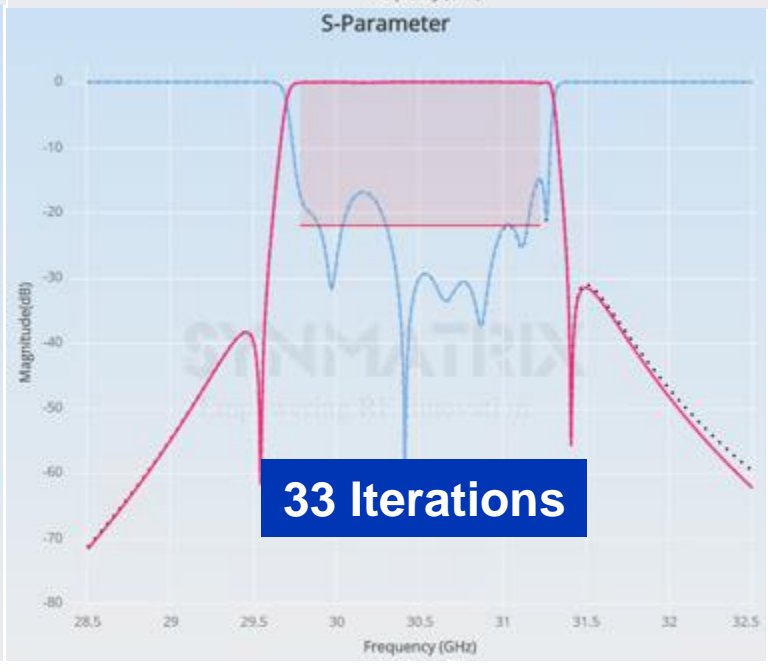

33 Iterations

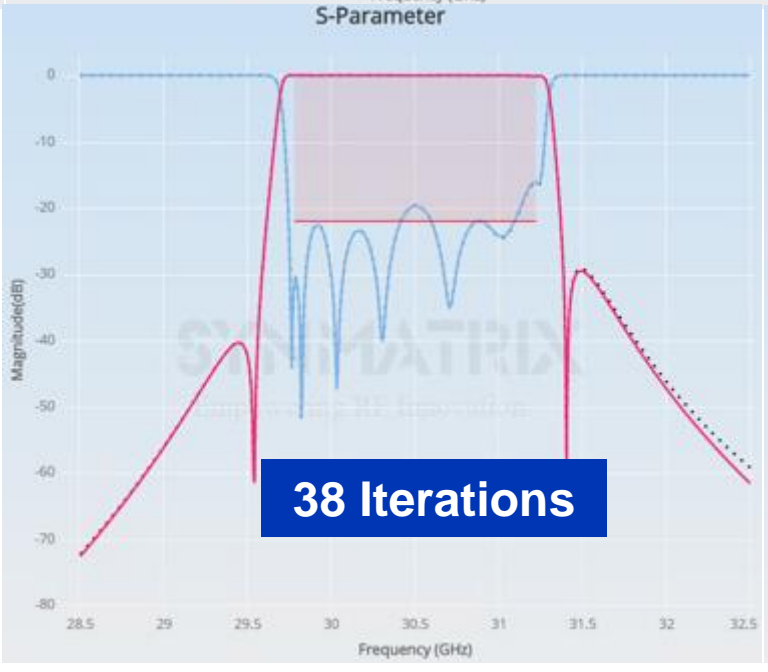

38 Iterations

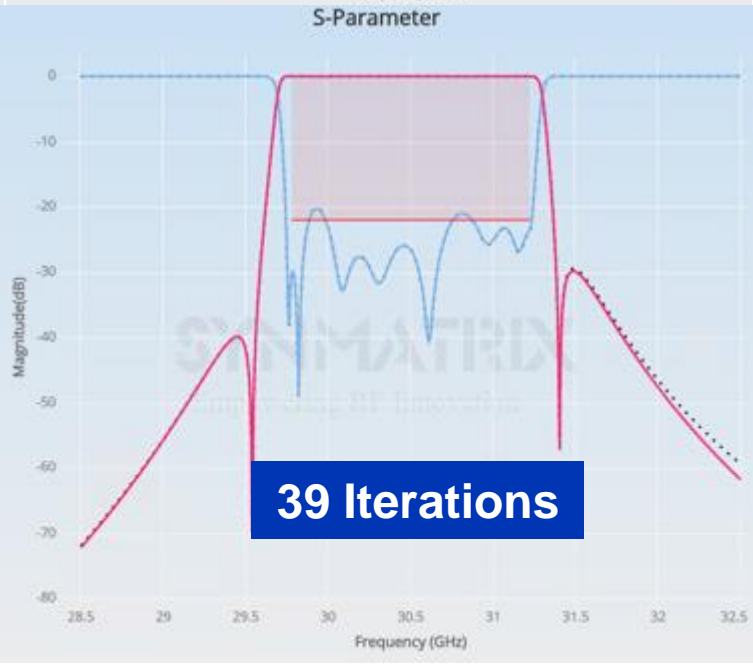

39 Iterations

Use Case 2b: AI Method

Waveguide Structure



Global Error For 6 Iterations Pass Optimization

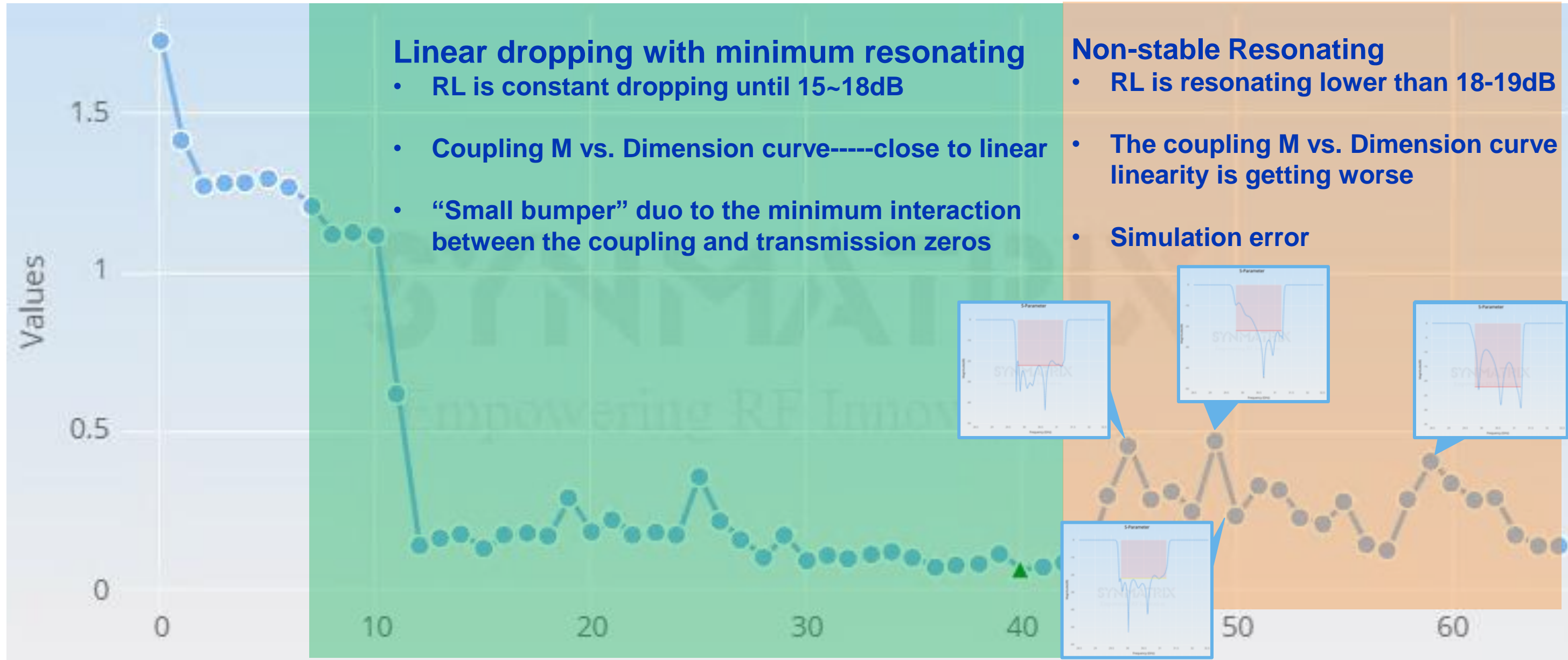

Use Case 2b: AI Method

Waveguide Structure



Increased meshes to increase the simulation accuracy and run the 2nd AI optimization

Pass Number	Solved Elements	Max Mag. Delta S
1	1392	N/A
2	1817	0.46282
3	2354	0.34388
4	3061	0.1984
5	3980	0.14976
6	5178	0.13048
7	6276	0.095313
8	7268	0.070806
9	9449	0.088933
10	12286	0.050432

Before

Now

Simulation setups:

- 10 iteration passes
- 801 points
- 4mins for each simulation

Total simulation: 1 hr 18mins

- 1st time AI: 53mins
- 2nd time AI: 25mins

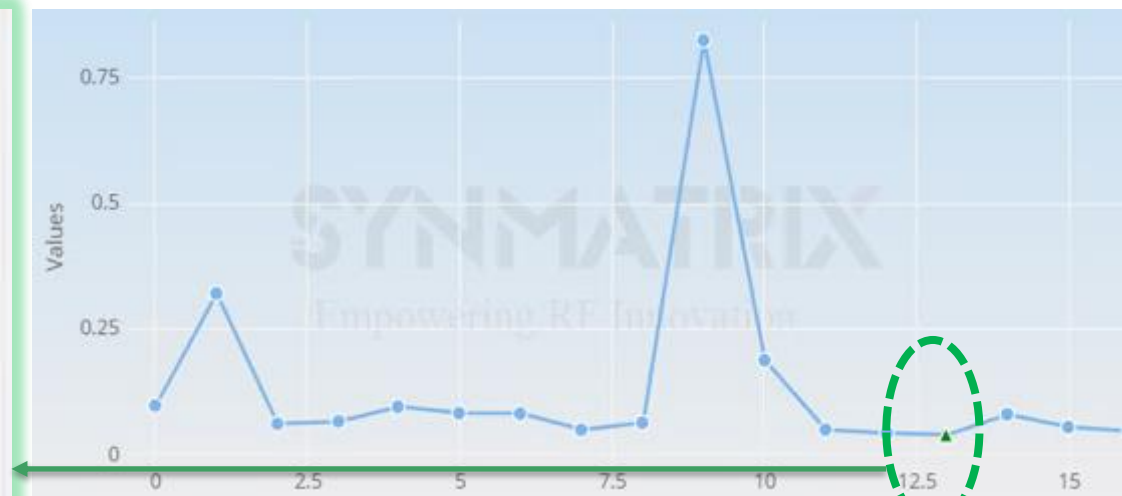
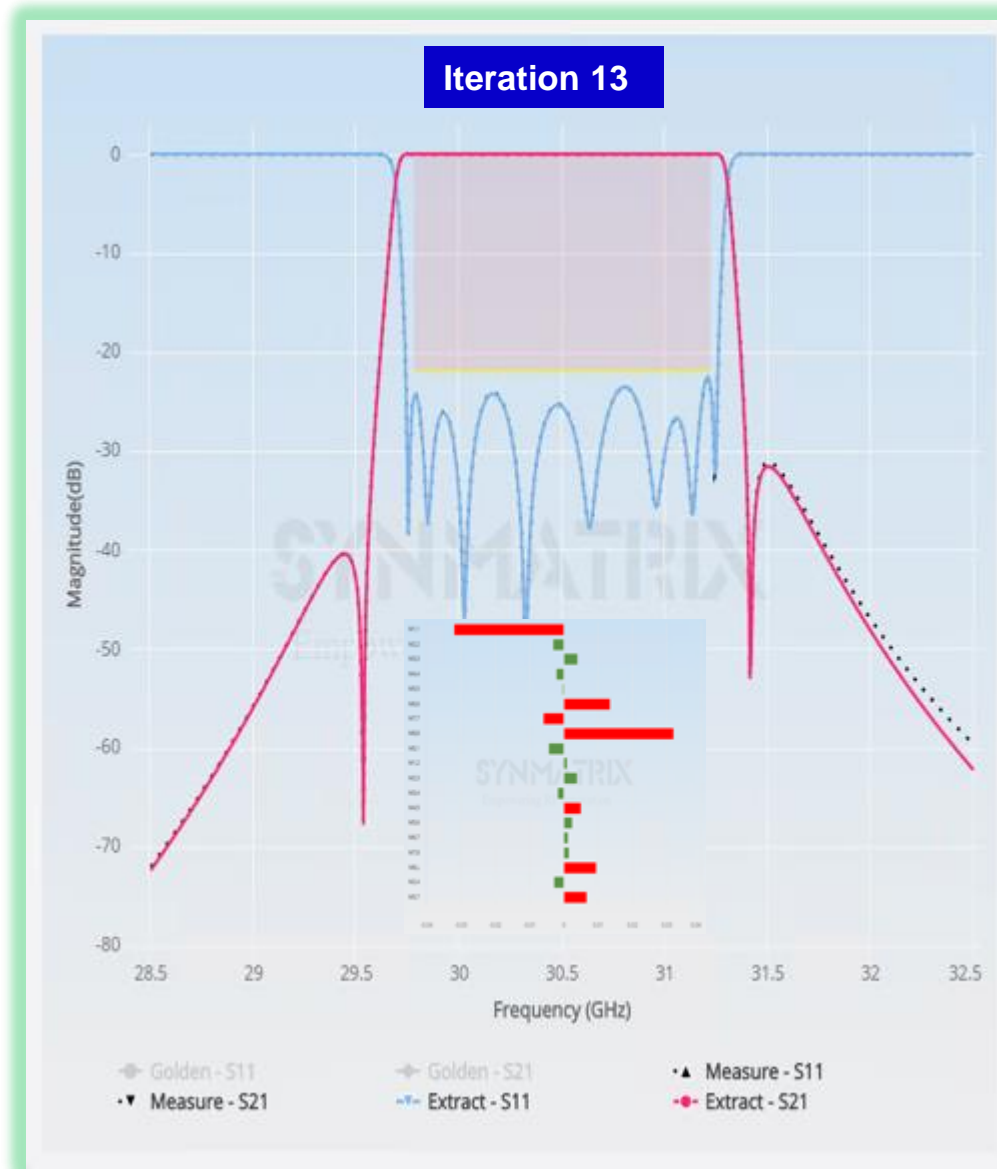

ParaName	Golden Matrix	Extract Matrix	Diff	ParaName	Golden Matrix	Extract Matrix	Diff
MS1	1.0828	1.0856	0.0028	f1	0.0271	0.0479	0.0208
M12	0.9021	0.9047	0.0026	f2	0.0273	0.0382	0.0109
M23	0.5102	0.5130	0.0027	f3	0.6479	0.6508	0.0029
M24	-0.3417	-0.3428	-0.0011	f4	0.0087	0.0142	0.0055
M34	0.4568	0.4605	0.0037	f5	0.0502	0.0532	0.0030
M45	0.5568	0.5574	0.0006	f6	-0.6841	-0.6834	0.0007
M56	0.4154	0.4188	0.0035	f7	0.0273	0.0256	-0.0016
M57	0.3943	0.3961	0.0017	f8	0.0271	0.0170	-0.0101
M67	0.4707	0.4702	-0.0006				
M78	0.9021	0.9066	0.0045				
M8L	1.0828	1.0829	0.0001				

Coupling differences are within 0.005;
Freq differences are within 0.012

Use Case 2c: AI Method

Dielectric Filled Waveguide---5G MIMO application



Design Spec: $f_0=3.55\text{GHz}$; $\text{BW}=1\text{GHz}$; $\text{RL}=18\text{dB}$; $\text{Tz}_1=-1.1$; $\text{Tz}_2=1.1$; $\text{Tz}_3=-1.5$; $\text{Tz}_4=1.5$; (Normalized)
 Estimated unloaded Q: 2000

Structure: Ceramic Waveguide;

Optimizer: AI Optimizer + Space mapping

Mapping Rules:

- ✓ I/O: Prob Depth
- ✓ Freq: blind hole
- ✓ Coupling: through hole width

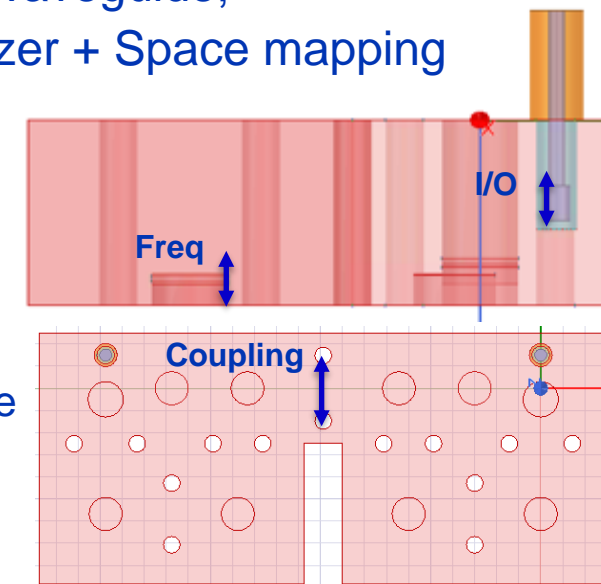

	S	1	2	3	4	5	6	7	8	L
S	0	0.9898	0	0	0	0	0	0	0	0
1	0.9898	0.0154	0.7898	0	-0.3327	0	0	0	0	0
2	0	0.7898	0.0154	0.8501	0	0	0	0	0	0
3	0	0	0.8501	0.0154	0.5022	0	0	0	0	0
4	0	-0.3327	0	0.5022	0.0154	0.5747	0	0	0	0
5	0	0	0	0	0.5747	0.0154	0.5602	0	-0.1606	0
6	0	0	0	0	0	0.5602	0.0154	0.7381	0	0
7	0	0	0	0	0	0	0.7381	0.0154	0.8418	0
8	0	0	0	0	0	0	0	0.8418	0.0154	0.9898
L	0	0	0	0	0	0	0	0	0.9898	0

Filter Order: 8 Start Frequency: 3.5 GHz Stop Frequency: 3.6 GHz Q Values: [Icon] Transmission-zeros: 4 Topology: [Icon] Dispersion: 2

Thermal Settings **Tips:** Thermal shift estimation

Material: Custom Range: -1.44 From (°C): -30 To (°C): 80

Thermal Shift (MHz): 0.2812 **Calculate**

ON	Refresh All	Sort	Add				
Type	Value(dB)	Start(GHz)	Stop(GHz)	LeftMargin	RightMargin	Status	Operation
RL (<)	-16	3.5	3.6	4.8489	5.1619	Pass	[Icon]
IL (>)	-1.95	3.5	3.6	0.8931	0.8371	Pass	[Icon]
iso (<)	-53	3.4	3.47	N/A	5.4854	Pass	[Icon]
iso (<)	-40	3.47	3.48	N/A	6.4886	Pass	[Icon]
iso (<)	-40	3.62	3.63	5.2571	N/A	Pass	[Icon]
iso (<)	-53	3.63	3.7	2.8719	N/A	Pass	[Icon]

Tips: Check to have enough frequency margins

Use Case 2c: AI Method

Dielectric Filled Waveguide

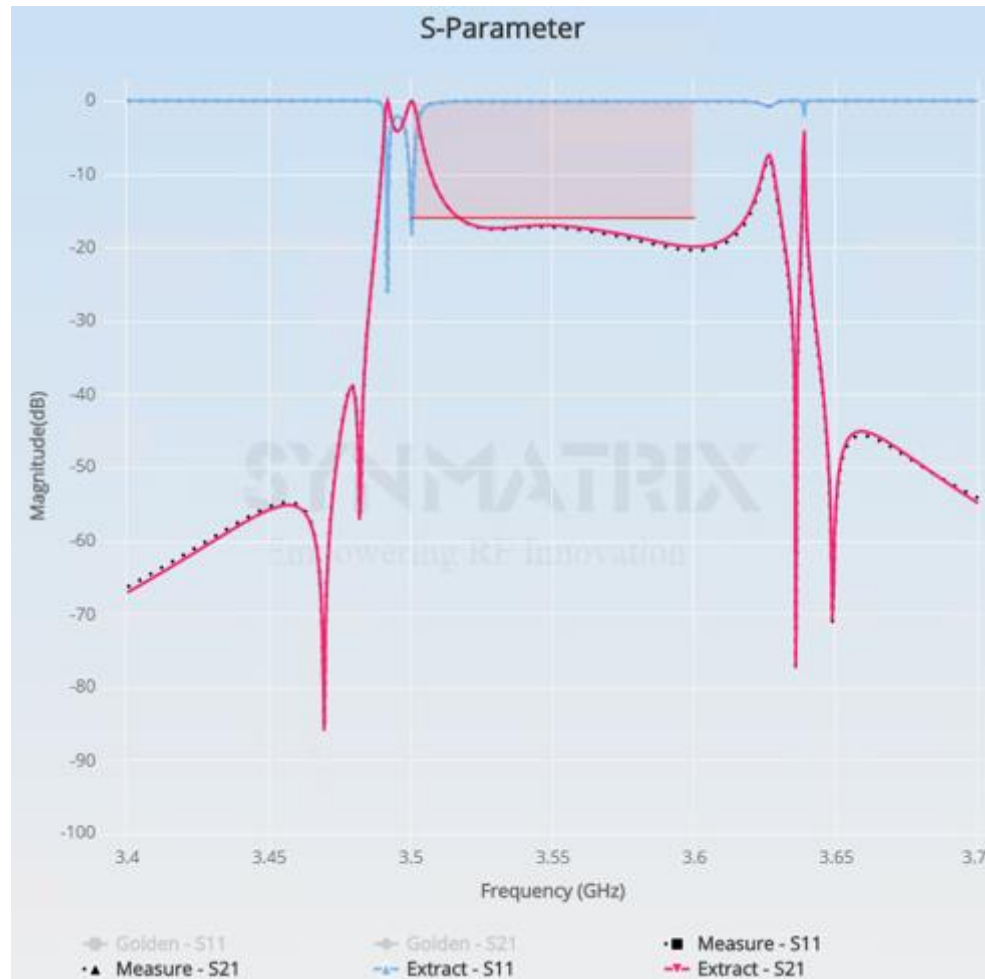

Initial Response



Coupling Matrix Error

Initial response

- Filter performance is detuned seriously
- Frequency error: higher than **0.5**
- Coupling error; higher than **0.1**
- Transmission zero error: higher than **0.08**

Set-up:

- HFSS:
 - ✓ Max No. Pass: 8
 - ✓ Max Delta S: 0.01
 - ✓ Sweep type: fast
 - ✓ Sweep Point: 701
- AI:
 - ✓ Trial Modification: 0.025
 - ✓ Maximum changes: 0.08
 - ✓ Convergent criterion: 0.01
 - ✓ Iteration Pass: 5
- **Each time simulation will cost 3mins 21seconds**

Use Case 2c: AI Method

Dielectric Filled Waveguide

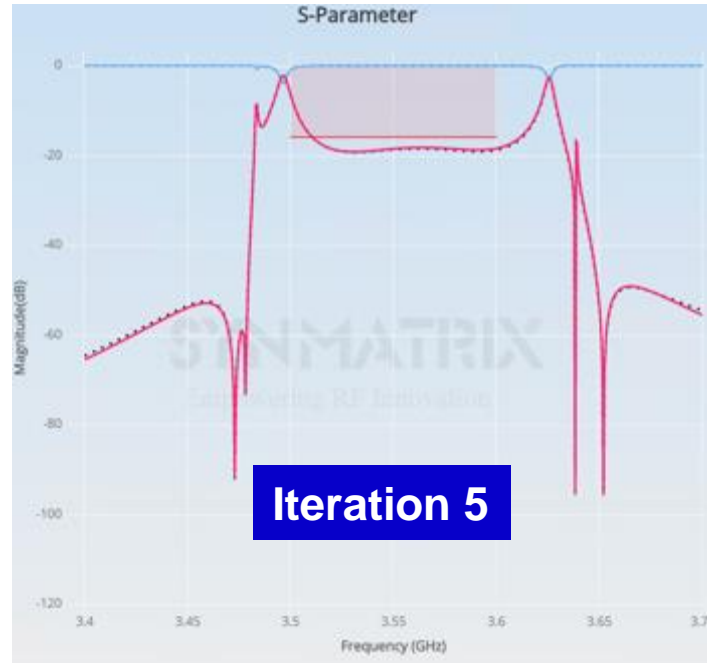

Iteration 5

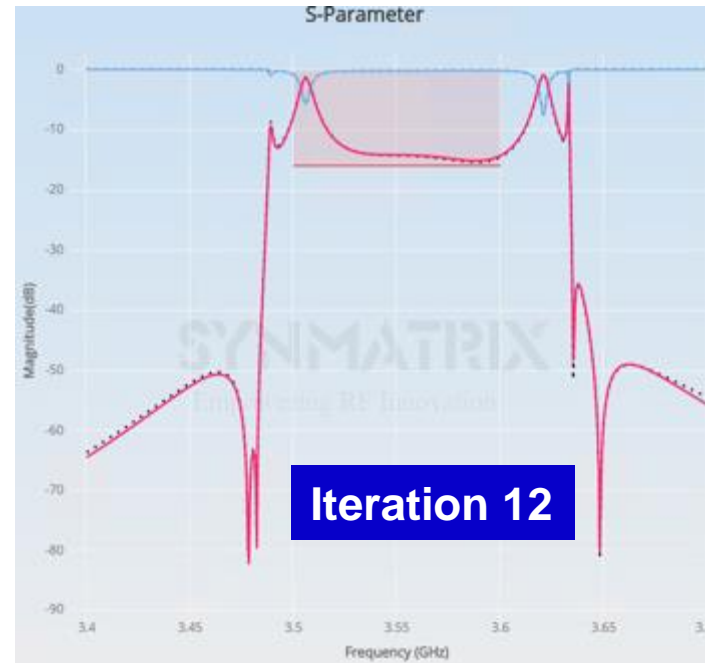

Iteration 12



Iteration 13

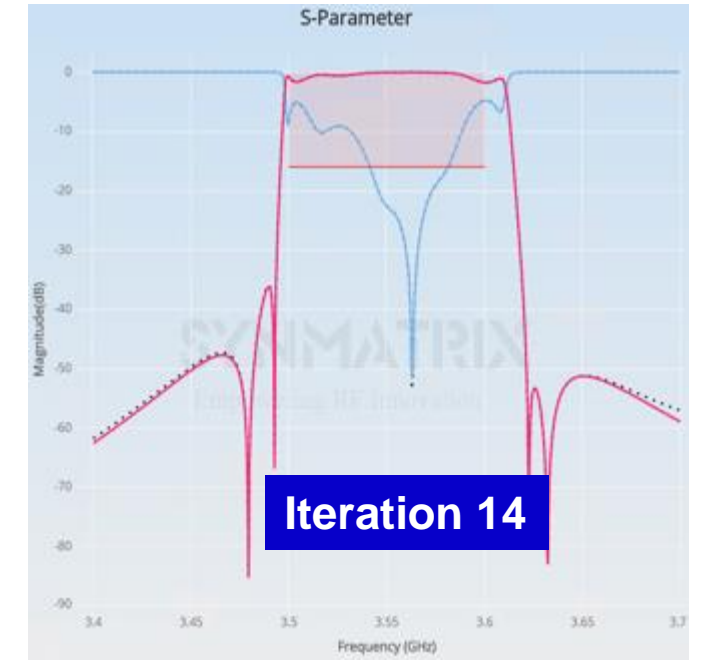

Iteration 14

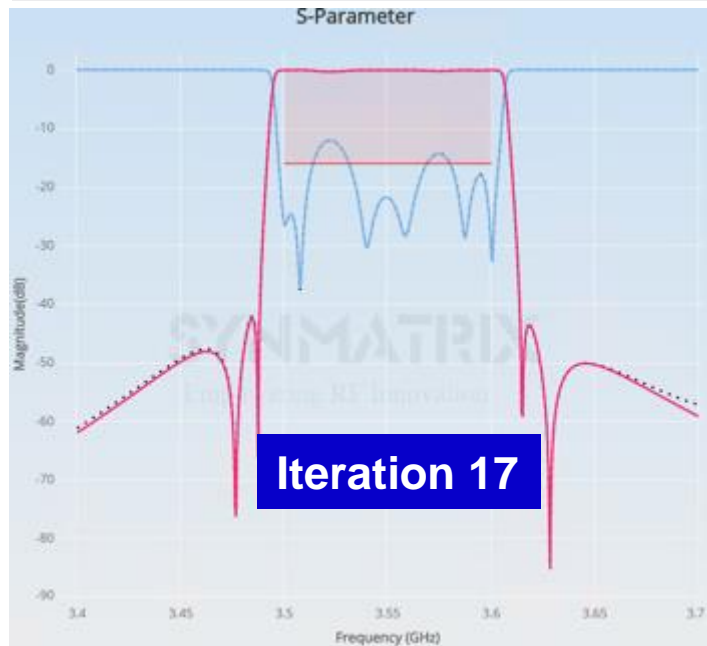

Iteration 17

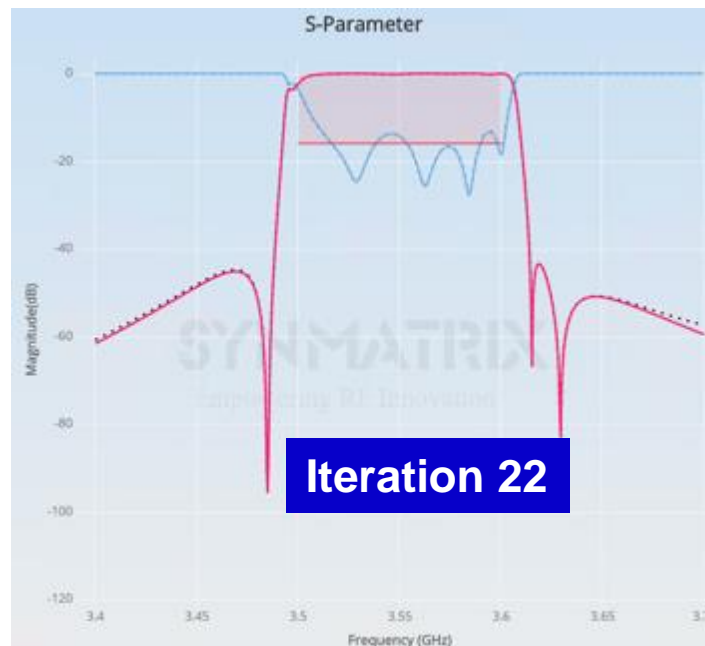

Iteration 22

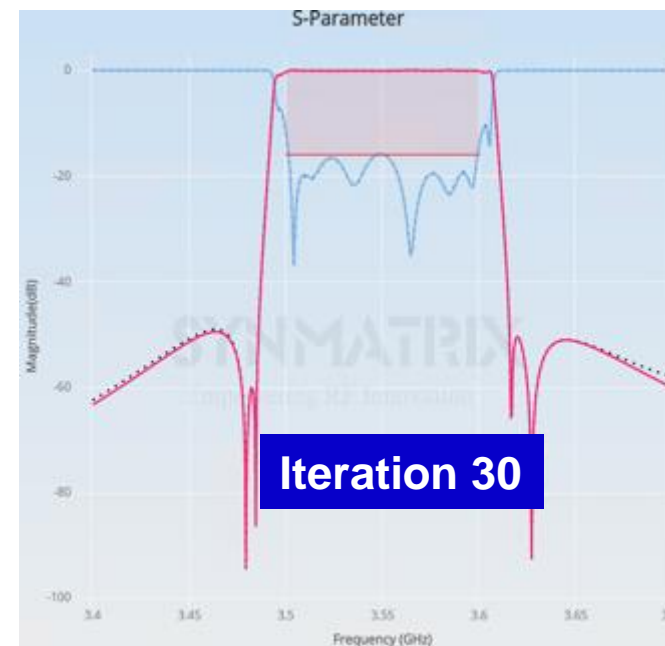

Iteration 30

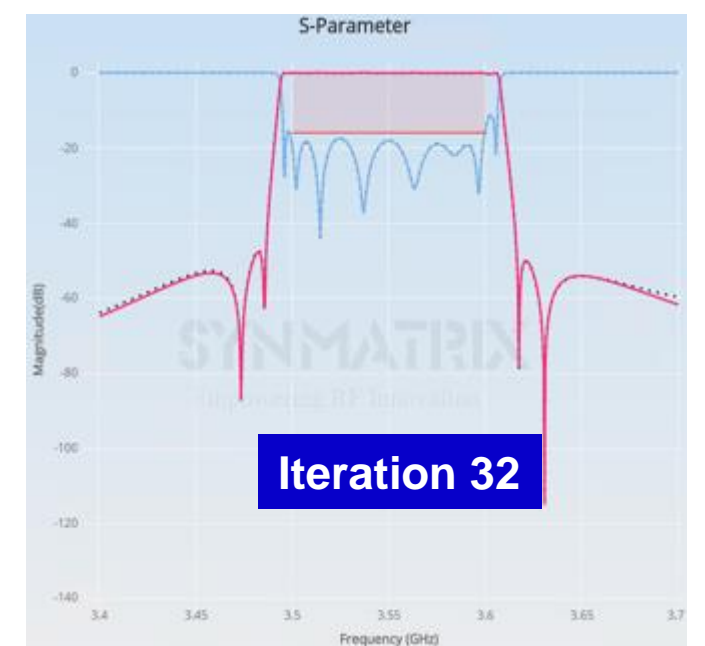

Iteration 32

Use Case 2c: AI Method

Dielectric Filled Waveguide

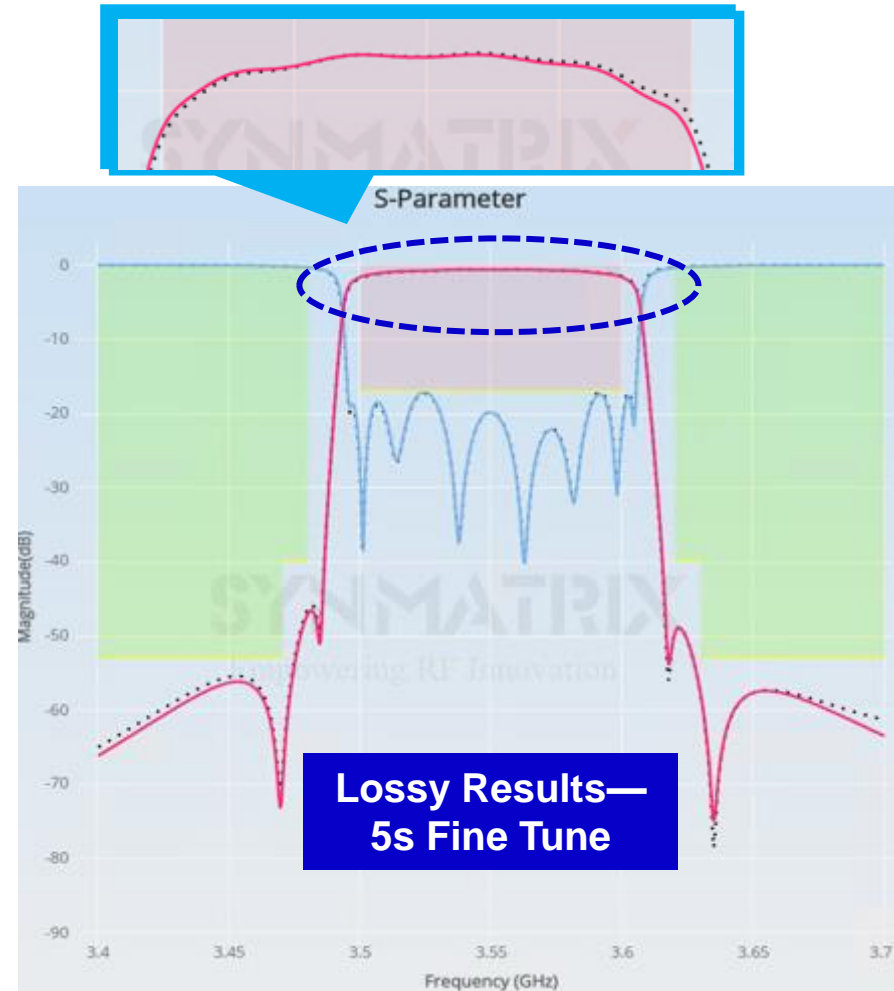
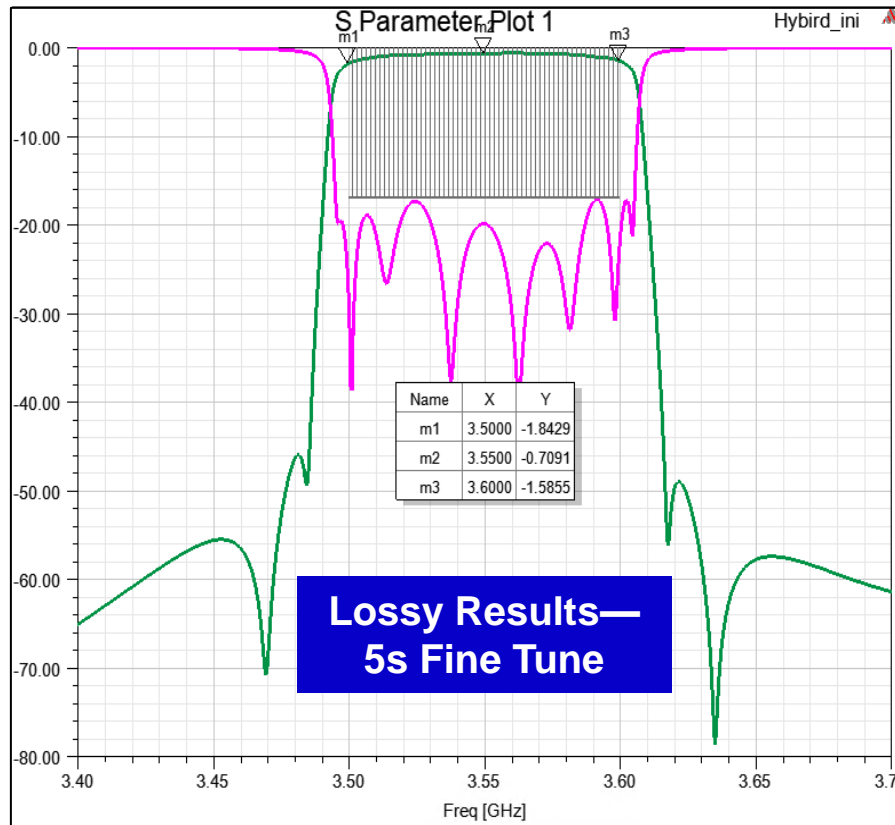

- Surface material is assigned to copper due to conservative consideration
- “Max iteration pass NO.” is increased to 10 to increase the simulation accuracy
- Frequency shifts down about 0.8Mhz; the extracted unloaded Q is 2200 compared with the designed 2000

Use Case 2c: AI Method

Dielectric Filled Waveguide

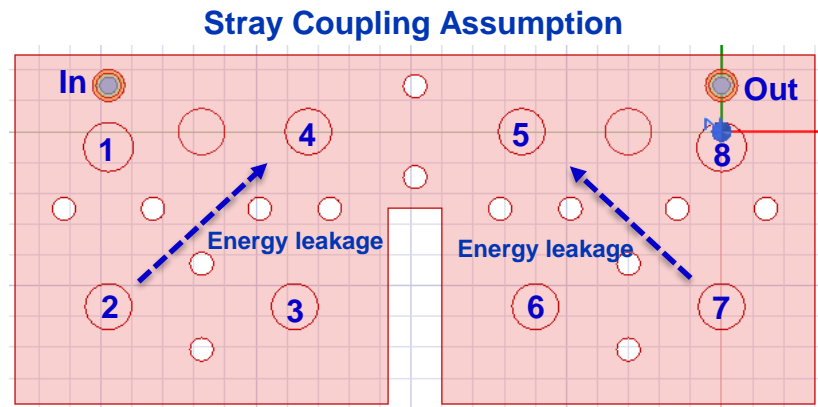

S	1	2	3	4	5	6	7	8	L
S	0	0.9938	0	0	0	0	0	0	0
1	0.9938	0.0449	0.7950	0	0	0	0	0	0
2	0	0.7950	0.0309	0.8521	0	0	0	0	0
3	0	0	0.8521	0.0360	0	0	0	0	0
4	0	-0.3295	-0.0144	0.5010	0.0271	0.5772	0	0	0
5	0	0	0	0	0.5772	0.0326	0.5653	-0.0070	-0.1606
6	0	0	0	0	0	0.5653	0.0240	0	0
7	0	0	0	0	0	-0.0070	0.7379	0.0372	0.8432
8	0	0	0	0	0	-0.1606	0	0.8432	0.0358
L	0	0	0	0	0	0	0	1.0011	0

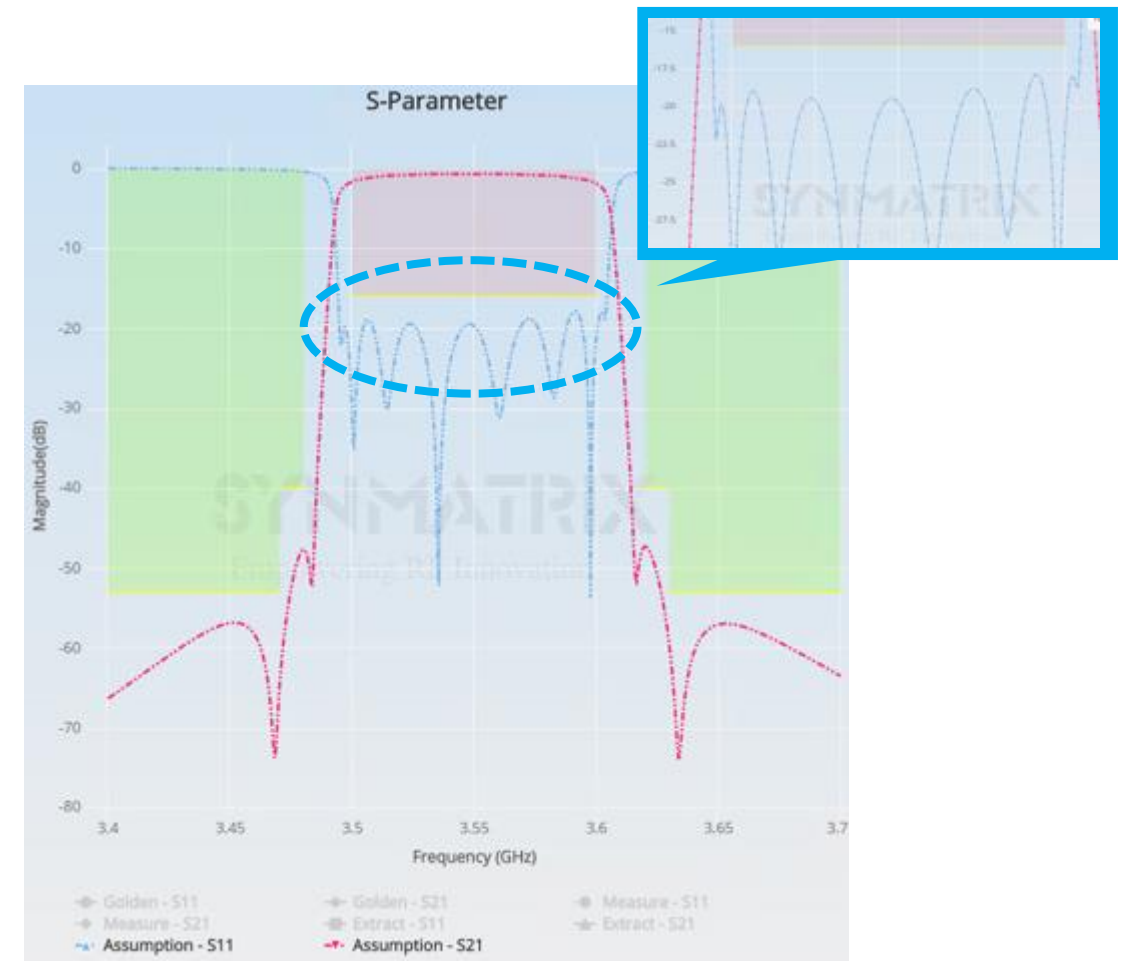

- “**Synmatrix Assumption**” allows user to predict the filter performance changing tendency and make the right choice during the tuning workflow
- The “**Stray coupling**” M24, M57 contributes the most for the in-band RL ripples